

16-Channel, 12-Bit PWM LED Driver with 6-Bit Dot Correction

FEATURES

- 16 Channels, Constant Current Sink Output
- 40-mA Capability (Constant Current Sink)
- 12-Bit (4096 Steps) Grayscale PWM Control
- 6-Bit (64 Steps) Dot Correction
- LED Power-Supply Voltage up to 17 V
- $V_{CC} = 3.0\text{ V to }5.5\text{ V}$
- **Constant Current Accuracy:**
 - Channel-to-Channel = $\pm 1\%$ (typ)
 - Device-to-Device = $\pm 2\%$ (typ)
- 30-MHz Data Transfer Rate
- 33-MHz Grayscale PWM Clock
- Extended Serial Interface
- CMOS Level I/O
- Schmitt Buffer Input
- **Readable Error Information:**
 - Continuous Base LED Open Detection (LOD)
 - Thermal Error Flag (TEF)
- **Noise Reduction:**
 - 4-Channel Grouped Delay
- **Operating Temperature: $-40^{\circ}\text{C to }+85^{\circ}\text{C}$**

APPLICATIONS

- Monochrome, Multicolor, Full-Color LED Displays
- LED Signboards
- Display Backlighting

DESCRIPTION

The TLC5946 is a 16-channel, constant current sink LED driver. Each channel is individually adjustable with 4096 pulse-width modulated (PWM) steps and 64 constant current sink steps for dot correction. The dot correction adjusts the brightness variations between LEDs. Both grayscale control and dot correction are accessible via a serial interface. The maximum current value of all 16 channels can be set by a single external resistor.

The TLC5946 has two error information circuits: one for LED open detection (LOD), and a thermal error flag (TEF). LOD detects a broken or disconnected LED during display period. TEF indicates an over-temperature condition.

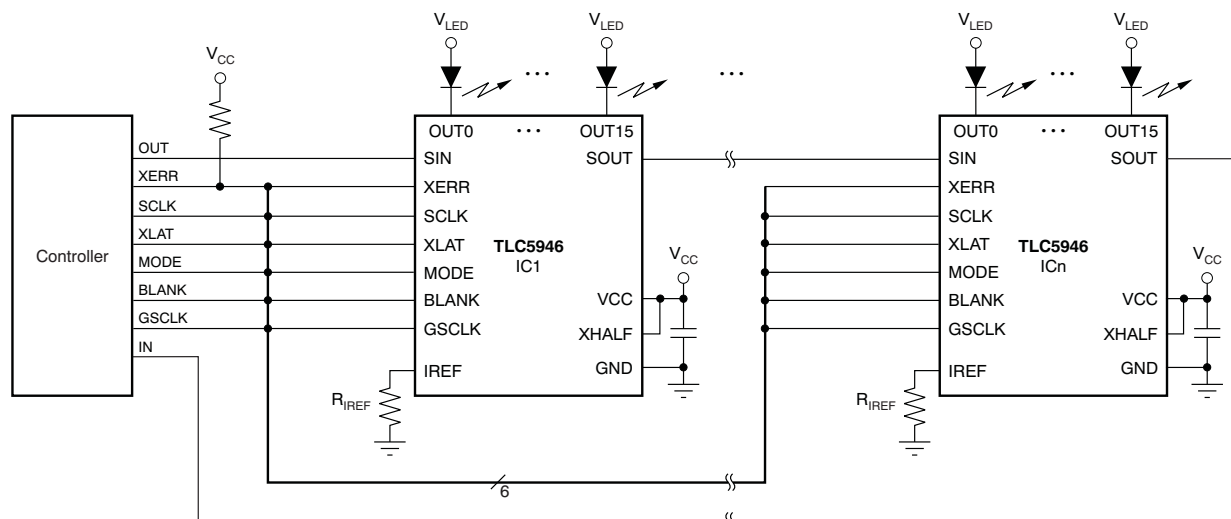

Typical Application Circuit (Multiple Daisy-Chained TLC5946s)



Please be aware that an important notice concerning availability, standard warranty, and use in critical applications of Texas Instruments semiconductor products and disclaimers thereto appears at the end of this data sheet.

PowerPAD is a trademark of Texas Instruments, Inc.
All other trademarks are the property of their respective owners.



This integrated circuit can be damaged by ESD. Texas Instruments recommends that all integrated circuits be handled with appropriate precautions. Failure to observe proper handling and installation procedures can cause damage.

ESD damage can range from subtle performance degradation to complete device failure. Precision integrated circuits may be more susceptible to damage because very small parametric changes could cause the device not to meet its published specifications.

PACKAGE/ORDERING INFORMATION⁽¹⁾

PRODUCT	PACKAGE-LEAD	ORDERING NUMBER
TLC5946	TSSOP-28	TLC5946PW
TLC5946	HTSSOP-28 PowerPAD™	TLC5946PWP
TLC5946	5 mm x 5 mm QFN-32	TLC5946RHB

- (1) For the most current package and ordering information see the Package Option Addendum at the end of this document, or see the TI web site at www.ti.com.

ABSOLUTE MAXIMUM RATINGS⁽¹⁾⁽²⁾

Over operating free-air temperature range, unless otherwise noted.

PARAMETER		TLC5946	UNIT
V_{CC}	Supply voltage: V_{CC}	-0.3 to +6.0	V
I_{OUT}	Output current (dc)	50	mA
	XERR	6	mA
V_{IN}	Input voltage range: SIN, SCLK, GSCLK, XLAT, BLANK, MODE, XHALF, IREF	-0.3 to $V_{CC} + 0.3$	V
V_{OUT}	Output voltage range	-0.3 to $V_{CC} + 0.3$	V
	SOUT, XERR	-0.3 to +18	V
$T_{J(ABS)}$	Operating temperature range: junction temperature	-40 to +150	°C
T_{STG}	Storage temperature range	-55 to +150	°C
ESD rating	Human body model (HBM), JEDEC JESD22-A114	2	kV
	Charged device model (CDM), JEDEC JESD22-C101	500	V

- (1) Stresses above these ratings may cause permanent damage. Exposure to absolute maximum conditions for extended periods may degrade device reliability. These are stress ratings only, and functional operation of the device at these or any other conditions beyond those specified is not supported.
- (2) All voltage values are with respect to network ground terminal.

DISSIPATION RATINGS

PACKAGE	OPERATING FACTOR ABOVE $T_A = +25^\circ\text{C}$	$T_A < +25^\circ\text{C}$ POWER RATING	$T_A = +70^\circ\text{C}$ POWER RATING	$T_A = +85^\circ\text{C}$ POWER RATING
TSSOP-28	16.21 mW/°C	2026 mW	1296 mW	1053 mW
HTSSOP-28 with PowerPAD soldered ⁽¹⁾	31.67 mW/°C	3958 mW	2533 mW	2058 mW
HTSSOP-28 with PowerPAD not soldered ⁽²⁾	16.21 mW/°C	2026 mW	1296 mW	1053 mW
QFN-32 ⁽³⁾	27.86 mW/°C	3482 mW	2228 mW	1811 mW

- (1) With PowerPAD soldered onto copper area on printed circuit board (PCB); 2 oz. copper. For more information, see [SLMA002](#) (available for download at www.ti.com).
- (2) With PowerPAD not soldered onto copper area on PCB.
- (3) The package thermal impedance is calculated in accordance with JESD51-5.

RECOMMENDED OPERATING CONDITIONS

At $T_A = -40^\circ\text{C}$ to $+85^\circ\text{C}$, unless otherwise noted.

PARAMETER		TEST CONDITIONS	TLC5946			UNIT
			MIN	NOM	MAX	
DC Characteristics: $V_{CC} = 3\text{ V to }5.5\text{ V}$						
V_{CC}	Supply voltage		3.0		5.5	V
V_O	Voltage applied to output	OUT0 to OUT15			17	V
V_{IH}	High-level input voltage		$0.7 \times V_{CC}$		V_{CC}	V
V_{IL}	Low-level input voltage		GND		$0.3 \times V_{CC}$	V
I_{OH}	High-level output current	SOUT			-1	mA
I_{OL}	Low-level output current	SOUT			1	mA
		XERR			5	mA
I_{OLC}	Constant output sink current	OUT0 to OUT15, DC = 3Fh	4		40	mA
T_A	Operating free-air temperature range		-40		+85	$^\circ\text{C}$
T_J	Operating junction temperature		-40		+125	$^\circ\text{C}$
AC Characteristics: $V_{CC} = 3\text{ V to }5.5\text{ V}$						
$f_{CLK} (sclk)$	Data shift clock frequency	SCLK, XHALF = H			30	MHz
		GSCLK, XHALF = L			15	MHz
$f_{CLK} (gsclk)$	Grayscale control clock frequency	GSCLK			33	MHz
T_{WH0} / T_{WL0}	SCLK pulse duration	SCLK = H/L (see Figure 12)	10			ns
T_{WH1} / T_{WL1}	GSCLK pulse duration	GSCLK = H/L (see Figure 12)	10			ns
T_{WH2}	XLAT pulse duration	XLAT = H (see Figure 12)	20			ns
T_{WH3}	BLANK pulse duration	BLANK = H (see Figure 12)	20			ns
T_{SU0}	Setup time	SIN–SCLK \uparrow (see Figure 12)	5			ns
T_{SU1}		XLAT \uparrow –SCLK \uparrow (see Figure 38, Figure 12)	100			ns
T_{SU2}		MODE–SCLK \uparrow (see Figure 12)	10			ns
T_{SU3}		MODE–XLAT \uparrow (see Figure 12)	10			ns
T_{SU4}		BLANK \downarrow –GSCLK \uparrow (see Figure 12)	10			ns
T_{SU5}		XLAT \uparrow –GSCLK \uparrow (see Figure 12)	30			ns
T_{SU6}		SCLK \downarrow –XLAT \uparrow (see Figure 38, Figure 12)	10			ns
T_{H0}	Hold time	SIN–SCLK \uparrow (see Figure 12)	3			ns
T_{H1}		MODE–SCLK \downarrow (see Figure 12)	10			ns
T_{H2}		MODE–XLAT \uparrow (see Figure 12)	100			ns
AC Characteristics: $V_{CC} = 3\text{ V to }5.5\text{ V}$, XHALF = L						
T_{WL2}	XLAT pulse duration	XLAT = L (see Figure 38)	20			ns
T_{SU7}	Setup time	BLANK \uparrow –XLAT \uparrow (see Figure 38)	20			ns
T_{H3}	Hold time	BLANK \downarrow –XLAT \downarrow (see Figure 38)	20			ns

ELECTRICAL CHARACTERISTICS

At $V_{CC} = 3.0\text{ V}$ to 5.5 V , $T_A = -40^\circ\text{C}$ to $+85^\circ\text{C}$, and $R_{IREF} = 1.3\text{ k}\Omega$. Typical values at $V_{CC} = 3.3\text{ V}$ and $T_A = +25^\circ\text{C}$, unless otherwise noted.

PARAMETER	TEST CONDITIONS	TLC5946			UNIT
		MIN	TYP	MAX	
V_{OH}	High-level output voltage	$I_{OH} = -1\text{ mA}$ at SOUT			V
V_{OL}	Low-level output voltage	$I_{OL} = 1\text{ mA}$ at SOUT			0.4
		$I_{OL} = 5\text{ mA}$ at XERR			0.5
I_{IN}	Input current	$V_{IN} = V_{CC}$ or GND at BLANK, XHALF, GSCLK, SCLK, SIN, XLAT, and MODE pins			-1
I_{CC1}	Supply current	No data transfer, all $OUT_n = \text{OFF}$, $V_{OUTn} = 1\text{ V}$, $DCn = 3Fh$, $R_{IREF} = 13\text{ k}\Omega$			0.9
I_{CC2}		No data transfer, all $OUT_n = \text{OFF}$, $V_{OUTn} = 1\text{ V}$, $DCn = 3Fh$, $R_{IREF} = 2.7\text{ k}\Omega$			4
I_{CC3}		Data transfer at 30 MHz, all $OUT_n = \text{ON}$, $V_{OUTn} = 1\text{ V}$, $DCn = 3Fh$, $R_{IREF} = 2.7\text{ k}\Omega$			13
I_{CC4}		Data transfer at 30 MHz, all $OUT_n = \text{ON}$, $V_{OUTn} = 1\text{ V}$, $DCn = 3Fh$			20
I_{OLC}	Constant output current	All $OUT_n = \text{ON}$, $V_{OUTn} = 1\text{ V}$, $V_{OUTfix} = 1\text{ V}$, $DCn = 3Fh$			35.5
I_{OLK1}	Output leakage current	All $OUT_n = \text{OFF}$, $V_{OUTn} = 17\text{ V}$, $DCn = 3Fh$ At OUT_0 to OUT_{15}			0.1
I_{OLK2}	Output leakage current	No error condition, $V_{XERR} = 5.5\text{ V}$, at XERR			1
ΔI_{OLC}	Constant current error (channel-to-channel) ⁽¹⁾	All $OUT_n = \text{ON}$, $V_{OUTn} = 1\text{ V}$, $V_{OUTfix} = 1\text{ V}$, $DCn = 3Fh$			± 1
ΔI_{OLC1}	Constant current error (device-to-device) ⁽²⁾	All $OUT_n = \text{ON}$, $V_{OUTn} = 1\text{ V}$, $V_{OUTfix} = 1\text{ V}$, $DCn = 3Fh$			± 2
ΔI_{OLC2}	Line regulation ⁽³⁾	All $OUT_n = \text{ON}$, $V_{OUTn} = 1\text{ V}$, $V_{OUTfix} = 1\text{ V}$, $V_{CC} = 3.0\text{ V}$ to 5.5 V , $DCn = 3Fh$			± 0.5
ΔI_{OLC3}	Load regulation ⁽⁴⁾	All $OUT_n = \text{ON}$, $V_{OUTn} = 1\text{ V}$ to 3 V , $V_{OUTfix} = 1\text{ V}$, $DCn = 3Fh$			± 1
T_{TEF}	Thermal error flag threshold	Junction temperature ⁽⁵⁾			+150
T_{HYS}	Thermal error hysteresis	Junction temperature ⁽⁵⁾			+5
V_{LOD}	LED open detection threshold	All $OUT_n = \text{ON}$			0.2
V_{IREF}	Reference voltage output				1.16

(1) The deviation of each output from the average of OUT_0 – OUT_{15} constant current. Deviation is calculated by the formula:

$$\Delta (\%) = \left[\frac{I_{OUTn}}{\frac{(I_{OUT0} + I_{OUT1} + \dots + I_{OUT15})}{16}} - 1 \right] \times 100$$

(2) The deviation of the OUT_0 – OUT_{15} constant current average from the ideal constant current value. Deviation is calculated by the following formula:

$$\Delta (\%) = \left[\frac{\frac{(I_{OUT0} + I_{OUT1} + \dots + I_{OUT14} + I_{OUT15})}{16} - (\text{Ideal Output Current})}{\text{Ideal Output Current}} \right] \times 100$$

Ideal current is calculated by the formula:

$$I_{OUT(\text{IDEAL})} = 42.5 \times \left[\frac{1.20}{R_{IREF}} \right]$$

(3) Line regulation is calculated by this equation:

$$\Delta (\%/V) = \left[\frac{(I_{OUTn} \text{ at } V_{CC} = 5.5\text{ V}) - (I_{OUTn} \text{ at } V_{CC} = 3.0\text{ V})}{(I_{OUTn} \text{ at } V_{CC} = 3.0\text{ V})} \right] \times \frac{100}{5.5\text{ V} - 3\text{ V}}$$

(4) Load regulation is calculated by the equation:

$$\Delta (\%/V) = \left[\frac{(I_{OUTn} \text{ at } V_{OUTn} = 3\text{ V}) - (I_{OUTn} \text{ at } V_{OUTn} = 1\text{ V})}{(I_{OUTn} \text{ at } V_{OUTn} = 1\text{ V})} \right] \times \frac{100}{3\text{ V} - 1\text{ V}}$$

(5) Not tested. Specified by design.

SWITCHING CHARACTERISTICS

At $V_{CC} = 3.0\text{ V to }5.5\text{ V}$, $T_A = -40^\circ\text{C to }+85^\circ\text{C}$, $C_{L0} = 15\text{ pF}$, $R_{L0} = 100\ \Omega$, $C_{L1} = 100\text{ pF}$, $R_{L1} = 1\text{ k}\Omega$, $R_{IREF} = 1.3\text{ k}\Omega$, $V_{LED} = 5\text{ V}$, and $V_{XERR} = 5\text{ V}$. Typical values at $V_{CC} = 3.3\text{ V}$ and $T_A = +25^\circ\text{C}$, unless otherwise noted.

PARAMETER		TEST CONDITIONS	TLC5946			UNIT
			MIN	TYP	MAX	
t_{R0}	Rise time	SOUT (see Figure 11)			16	ns
t_{R1}		OUTn, $V_{CC} = 5\text{ V}$, DC = 3Fh (see Figure 11)		10	30	
t_{F0}	Fall time	SOUT (see Figure 11)			16	ns
t_{F1}		OUTn, $V_{CC} = 5\text{ V}$, DC = 3Fh (see Figure 11)		10	30	
t_{F2}		XERR (see Figure 11)			100	ns
t_{D0}	Propagation delay time	SCLK to SOUT (see Figure 12) ⁽¹⁾			25	ns
t_{D1}		BLANK \uparrow to OUT0 sink current off (see Figure 12)		20	40	ns
t_{D2}		GSCLK \uparrow to OUT0/4/8/12 (see Figure 12)	5	18	40	ns
t_{D3}		GSCLK \uparrow to OUT1/5/9/13 (see Figure 12)	20	42	73	ns
t_{D4}		GSCLK \uparrow to OUT2/6/10/14 (see Figure 12)	35	66	106	ns
t_{D5}		GSCLK \uparrow to OUT3/7/11/15 (see Figure 12)	50	90	140	ns
t_{D6}		XLAT \uparrow to OUTn (dot correction) 00h to 3Fh, 3Fh to 00h (see Figure 12)			100	ns
t_{ON_ERR}	Output on-time error	$t_{OUTON} - t_{GSCLK}$, GS $n = 001h$, GSCLK = 33 MHz (see Figure 13)	-20		10	ns

(1) XHALF = H: rising edge of SCLK to SOUT; XHALF = L: falling edge of SCLK to SOUT.

FUNCTIONAL BLOCK DIAGRAM

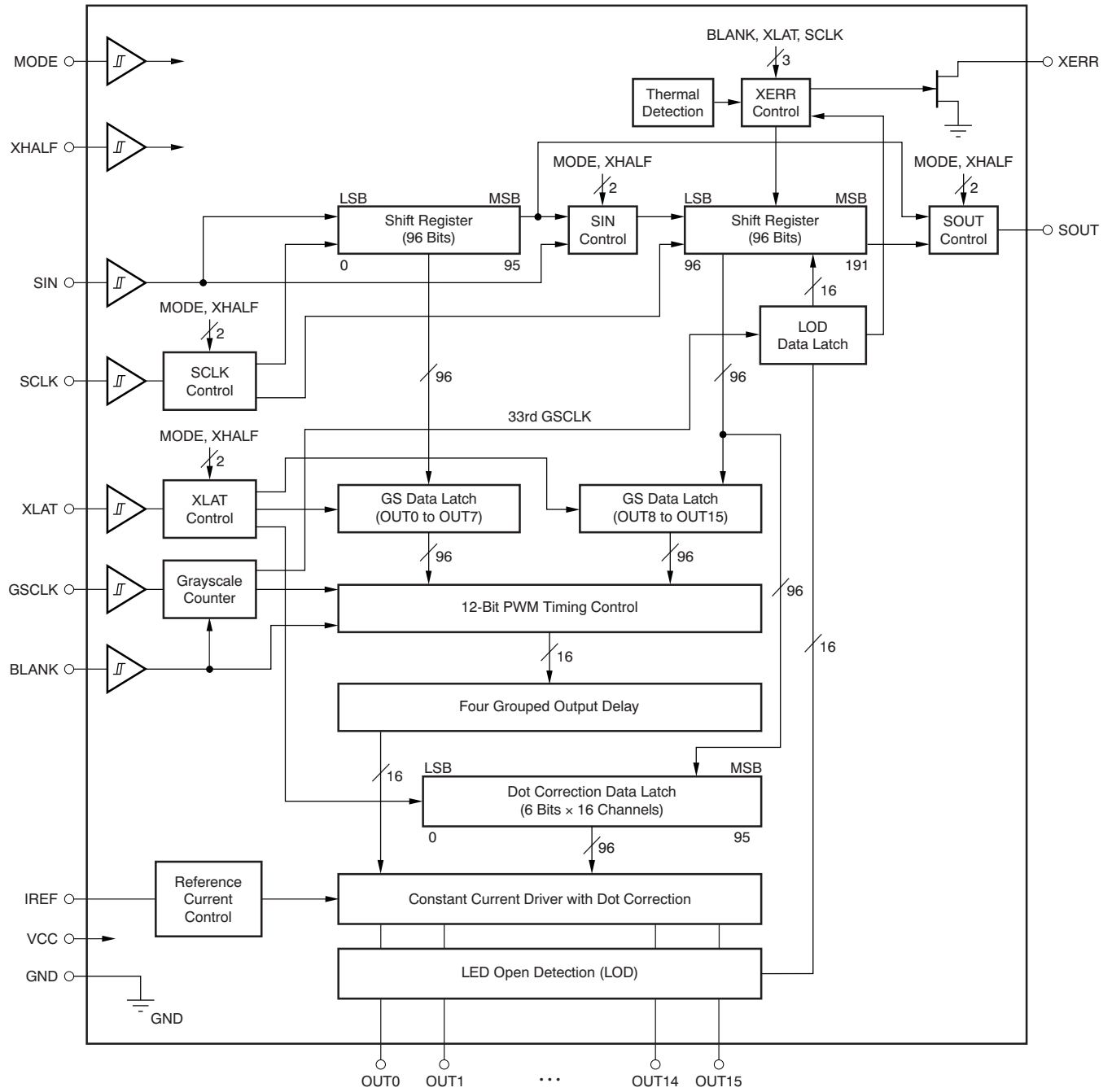

DEVICE INFORMATION

**TSSOP-28
PW PACKAGE
(TOP VIEW)**

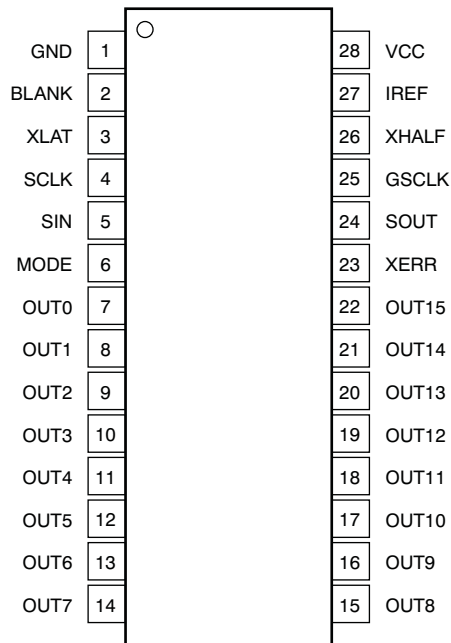

**HTSSOP-28
PWP PACKAGE
(TOP VIEW)**

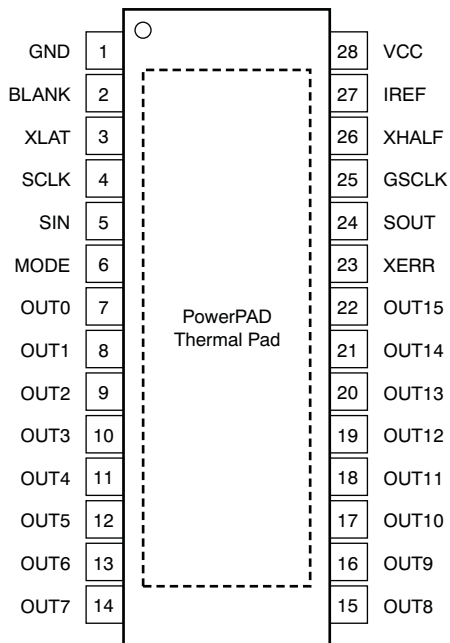

**QFN-32
RHB PACKAGE
(TOP VIEW)**

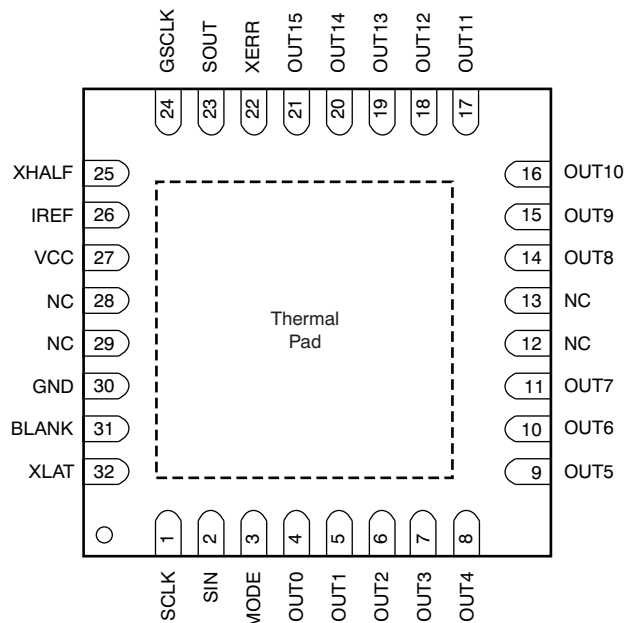

NC = No internal connection.

TERMINAL FUNCTIONS

TERMINAL			I/O	DESCRIPTION
NAME	PW/PWP	RHB		
BLANK	2	31	I	Blank (all constant current outputs off). When BLANK is high, all constant current outputs (OUT0 through OUT15) are forced off, the Grayscale PWM timing controller initializes and the Grayscale counter resets to '0'. When BLANK is low, all constant current outputs are controlled by the Grayscale PWM timing controller.
GND	1	30	—	Ground
GSCCLK	25	24	I	Reference clock for Grayscale PWM control.
IREF	27	26	I/O	This pin sets the constant current value. OUT0 through OUT15 sink constant current is set to desired value by connecting an external resistor between IREF and GND.
MODE	6	3	I	Input mode pin. When MODE is high, the input mode is dot correction (DC). When MODE is low, the input mode is grayscale (GS).
NC	—	12, 13, 28, 29	—	No connection
OUT0	7	4	O	Constant current output
OUT1	8	5	O	Constant current output
OUT2	9	6	O	Constant current output
OUT3	10	7	O	Constant current output
OUT4	11	8	O	Constant current output
OUT5	12	9	O	Constant current output
OUT6	13	10	O	Constant current output
OUT7	14	11	O	Constant current output
OUT8	15	14	O	Constant current output
OUT9	16	15	O	Constant current output
OUT10	17	16	O	Constant current output
OUT11	18	17	O	Constant current output
OUT12	19	18	O	Constant current output
OUT13	20	19	O	Constant current output
OUT14	21	20	O	Constant current output
OUT15	22	21	O	Constant current output
SCLK	4	1	I	Serial data shift clock
SIN	5	2	I	Serial data input
SOUT	24	23	O	Serial data output
VCC	28	27	I	Power-supply voltage
XERR	23	22	O	Error output. Open-drain output. XERR goes low when LOD or TEF is detected.
XHALF	26	25	I	Extended serial interface. When XHALF is high, the device operates normally. When XHALF is low, the extended serial interface is activated.
XLAT	3	32	I	Edge triggered latch signal. At the rising edge of XLAT, the TLC5946 writes data from the input shift register to either the Dot Correction register (MODE = high) or the Grayscale register (MODE = low).

PARAMETER MEASUREMENT INFORMATION

PIN EQUIVALENT INPUT AND OUTPUT SCHEMATIC DIAGRAMS

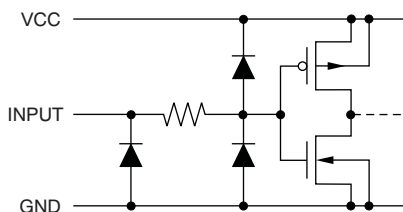

Figure 1. SIN, SCLK, GSCLK, XLAT, BLANK, MODE, XHALF

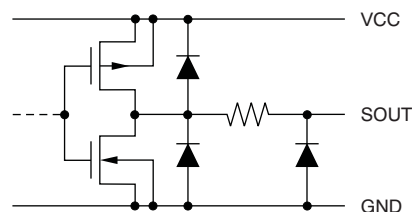

Figure 2. SOUT

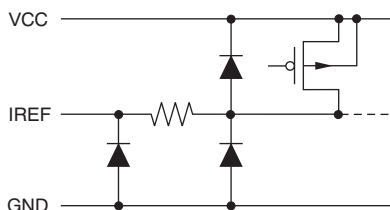

Figure 3. IREF

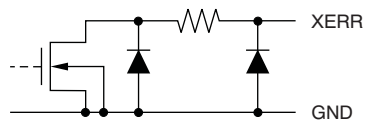

Figure 4. XERR

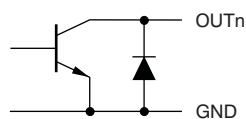
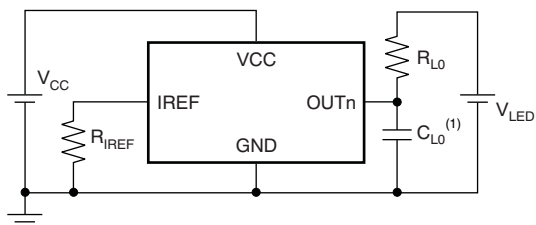

Figure 5. OUT0 Through OUT15

TEST CIRCUITS



(1) C_{L0} includes measurement probe and jig capacitance.

Figure 6. Rise Time and Fall Time Test Circuit for OUTn

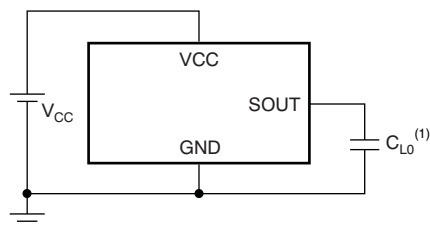

(1) C_{L0} includes measurement probe and jig capacitance.

Figure 7. Rise Time and Fall Time Test Circuit for SOUT

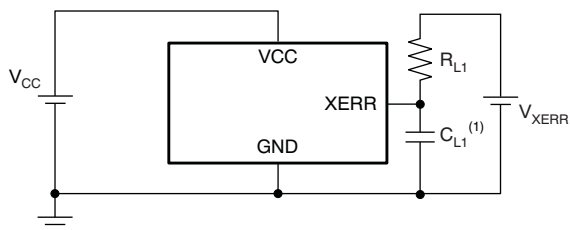

(1) C_{L1} includes measurement probe and jig capacitance.

Figure 8. Rise Time and Fall Time Test Circuit for XERR

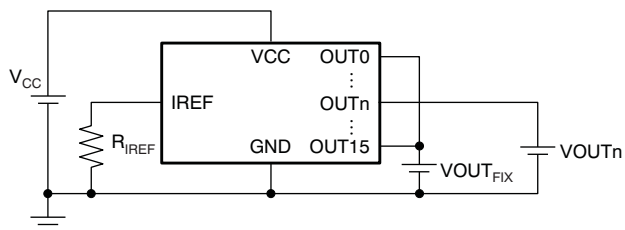
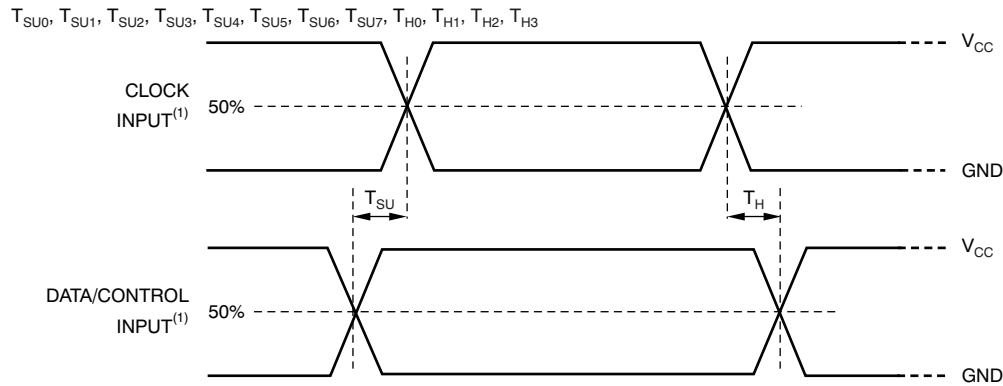
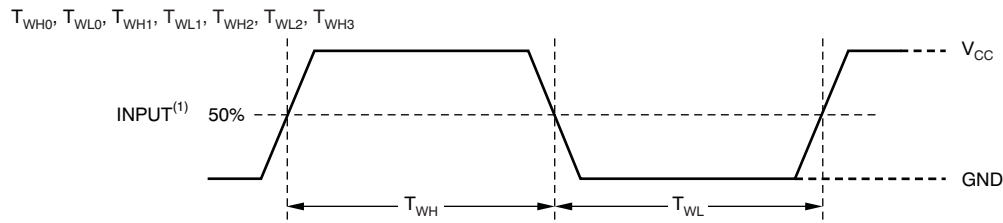

Figure 9. Constant Current Test Circuit for OUTn

TIMING DIAGRAMS



(1) Input pulse rise and fall time is 1 ns to 3 ns. Input pulse high level is VCC and low level is GND.

Figure 10. Input Timing

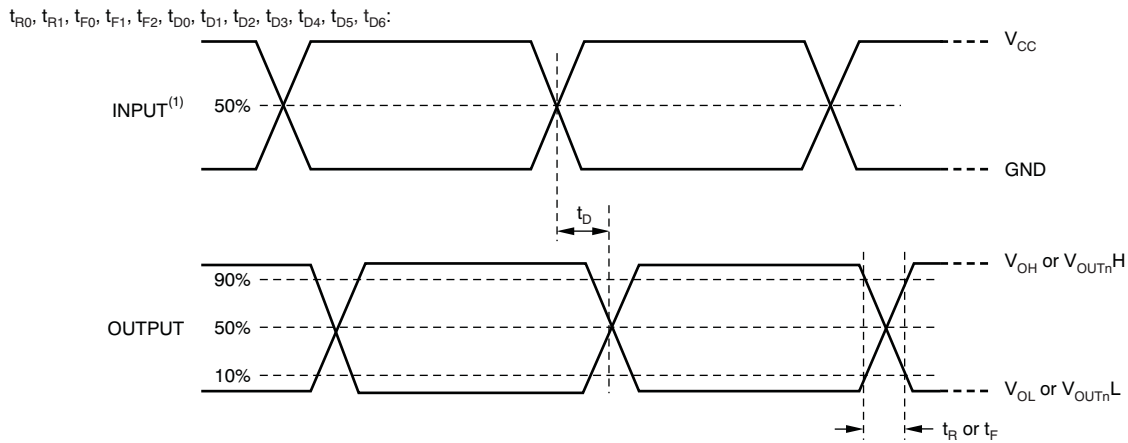

(1) Input pulse rise and fall time is 1 ns to 3 ns.

Figure 11. Output Timing

TYPICAL CHARACTERISTICS

At $V_{CC} = 3.3\text{ V}$ and $T_A = +25^\circ\text{C}$, unless otherwise noted.

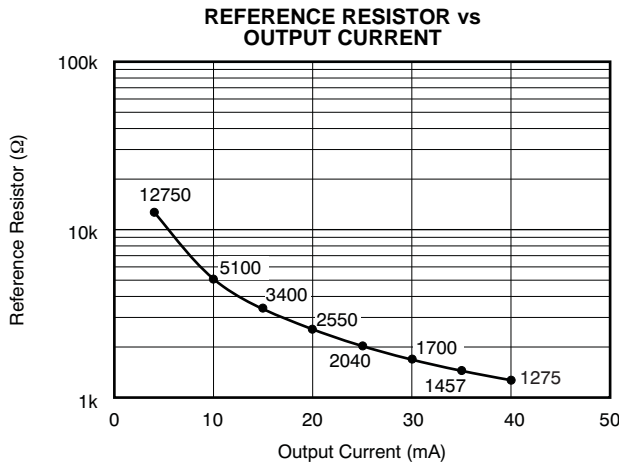

Figure 14.

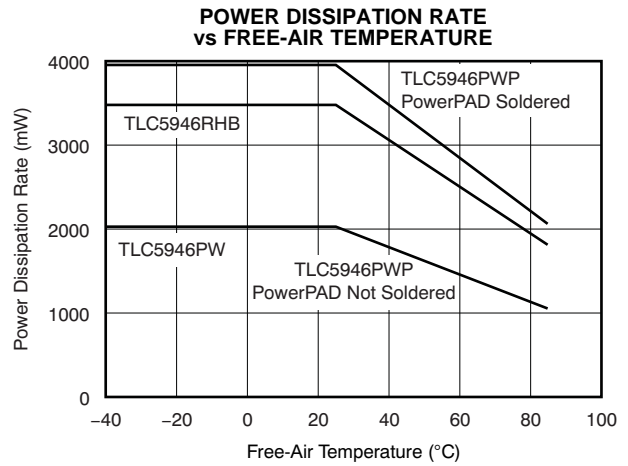

Figure 15.

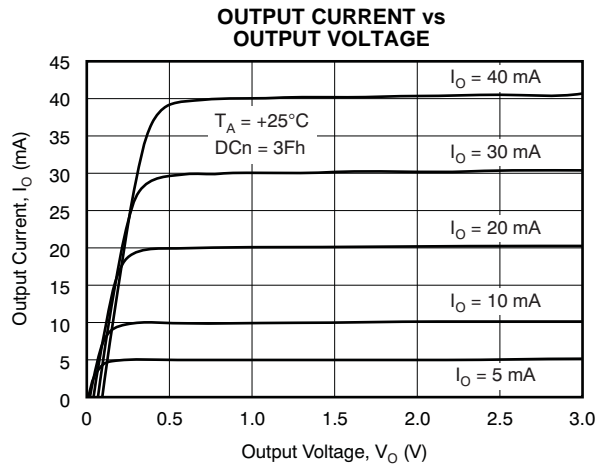

Figure 16.

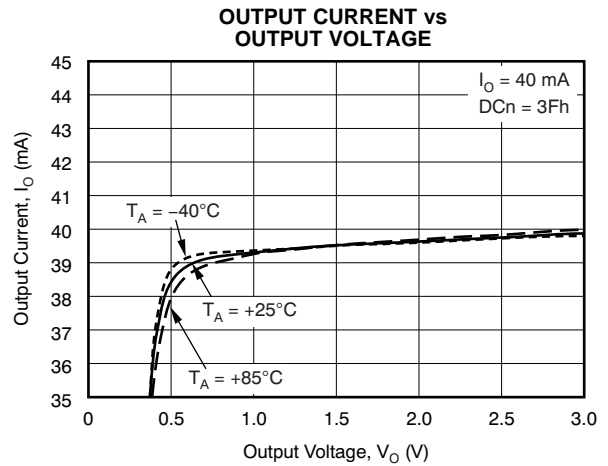

Figure 17.

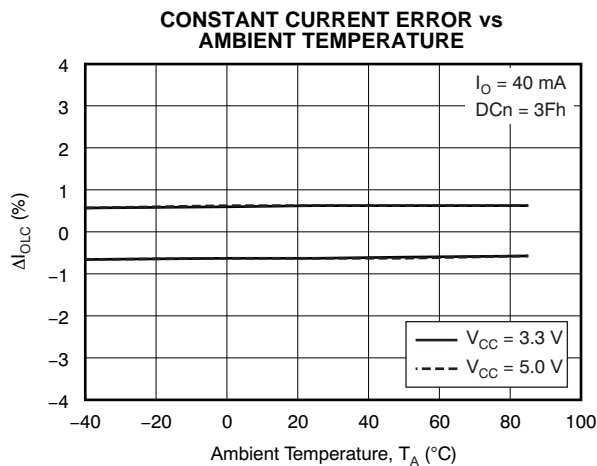

Figure 18.

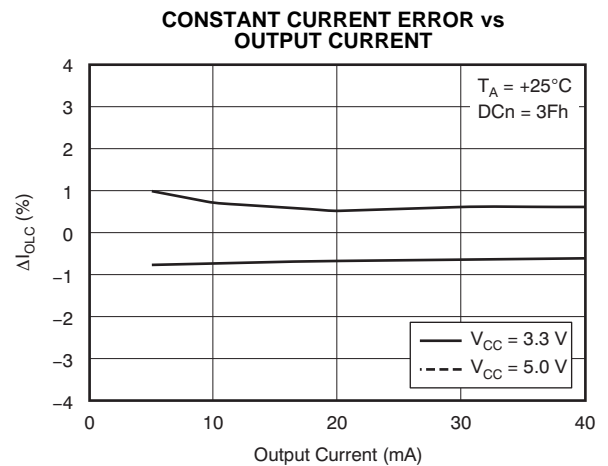

Figure 19.

TYPICAL CHARACTERISTICS (continued)

At $V_{CC} = 3.3\text{ V}$ and $T_A = +25^\circ\text{C}$, unless otherwise noted.

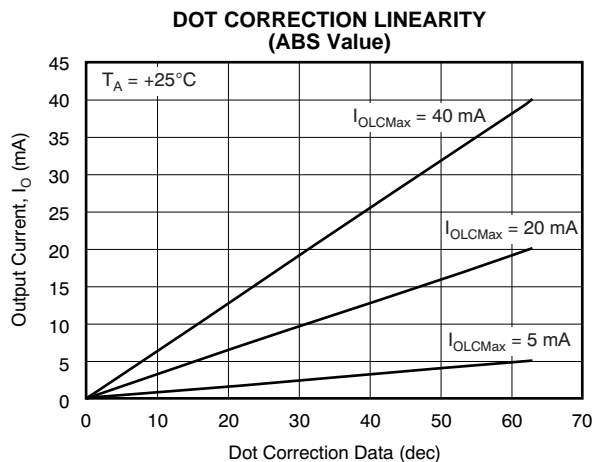

Figure 20.

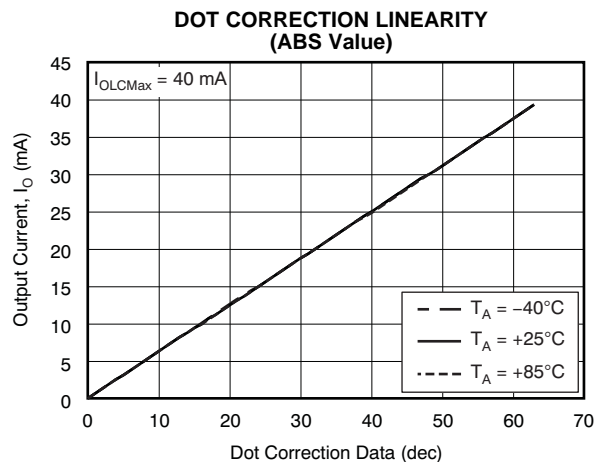

Figure 21.

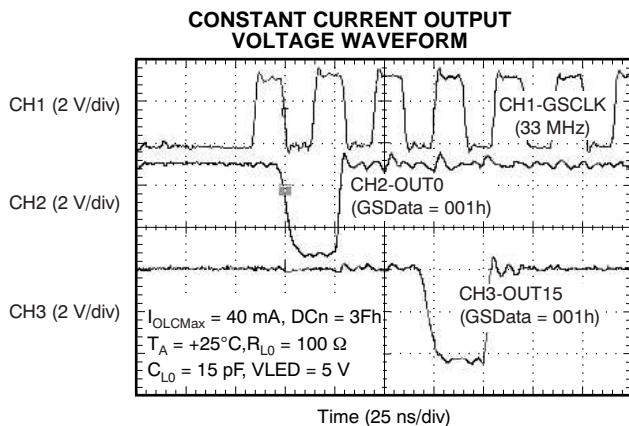

Figure 22.

DETAILED DESCRIPTION

SETTING FOR THE MAXIMUM OUTPUT CURRENT VALUE

The maximum output current of each channel (I_{OLCMax}) is set by a single external resistor (R_{IREF}), placed between the IREF pin and the GND pin. The voltage on IREF is made with an internal bandgap, V_{IREF} , which has a typical value of 1.20 V. The R_{IREF} resistor value is calculated by [Equation 1](#):

$$R_{IREF} (\Omega) = 42.5 \times \frac{V_{IREF} (V)}{I_{OLCMax} (mA)} \quad (1)$$

Where:

- $V_{IREF} = 1.20 \text{ V}$
- $R_{IREF} = \text{User-selected external resistor}$

I_{OLCMax} is the largest current for all outputs. Each output sinks the I_{OLCMax} current when it is turned on and its dot correction is set to the maximum value of 3Fh (63d). The sink current for each output can be reduced by lowering the respective output dot correction value.

R_{IREF} must be between 1.275 k Ω (typ) and 12.75 k Ω (typ) in order to keep I_{OLCMax} between 4 mA and 40 mA. The output current may be unstable if I_{OLCMax} is less than 4 mA. Output currents lower than 4 mA can be achieved by setting I_{OLCMax} to 4 mA or higher and then using dot correction.

[Figure 14](#) illustrates the maximum output current versus R_{IREF} . R_{IREF} is the value of the resistor between the IREF terminal to GND. A variable power supply may be connected to the IREF pin through a resistor to change the maximum output current per output. The maximum output current is 42.5 times the current flowing out of the IREF pin.

DOT CORRECTION (DC) FUNCTION

The TLC5946 is able to individually adjust the output current of each channel (OUT0 to OUT15). This function is called *dot correction* (DC). The DC function allows the user to individually adjust the brightness and color deviations of LEDs connected to the outputs OUT0 to OUT15. Each respective channel output current can be adjusted in 64 steps from 0% to 100% of the maximum output current, I_{OLCMax} . The dot correction data are entered into the TLC5946 via the serial interface.

The output current is calculated by [Equation 2](#):

$$I_{OUTn} = I_{OLCMax} \times \frac{DCn}{63} \quad (2)$$

Where:

- I_{OLCMax} = the maximum output current of each output
- DCn = the programmed dot correction value of output n ($DCn = 0$ to 63)

When MODE is high, the input shift register works as a DC shift register. The shift registers and data latches are each 96 bits in length, and are used to individually adjust the constant current values for each constant current driver. Each channel can be adjusted from 0% to 100% of the maximum LED current with 6-bit resolution. [Figure 23](#) illustrates the DC serial data configuration. [Figure 12](#) illustrates the timing chart for writing data into the shift registers and data latches. Each channel LED current is dot-corrected by the percentage corresponding to the data in its DC data latch. DC data present on the SIN pin are clocked into the shift register with each rising edge of the SCLK pin. Data are shifted in MSB first. The data are latched from the shift register into the DC data latch with a rising edge on the XLAT pin.

The BLANK signal does not need to be high to latch in new data. When XLAT goes high, the new dot-correction data immediately become valid and change the output currents if the output is on. When the IC is powered on, the data in the shift register and DC data latch are not set to any default values. Therefore, DC data must be written to the DC latch before turning on the constant current output.

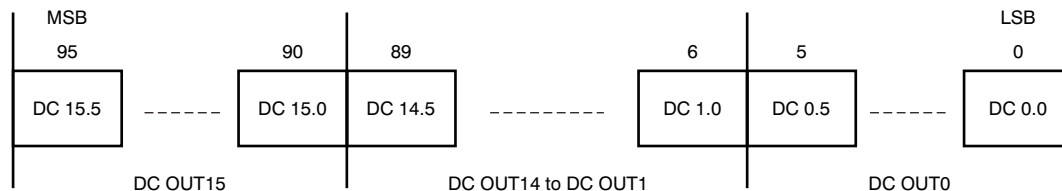

Figure 23. Dot Correction Serial Data Configuration

GRAYSCALE (GS) FUNCTION (PWM Operation)

The pulse width modulation (PWM) operation is controlled by a 12-bit grayscale counter that is clocked on each rising edge of the grayscale reference clock (GSCLK). The counter is reset to zero when the BLANK signal is set high. The counter value is held at zero while BLANK is high, even if the GSCLK input toggles high and low. After the falling edge of BLANK, the counter increments with each rising edge of GSCLK. Any constant current sink output (OUT0 through OUT15) with a non-zero value in its corresponding grayscale latch starts to sink current after the first rising edge of GSCLK following a high-to-low transition of BLANK. The internal counter keeps track of the number of GSCLK pulses. Each output channel stays on as long as the internal counter is equal to or less than the respective output GS data. Each channel turns off at the rising edge of GSCLK when the grayscale counter value is larger than the grayscale latch value.

For example, an output that has a grayscale latch value of '1' turns on at the first rising edge of GSCLK after BLANK goes low. It turns off at the second rising edge of GSCLK. Figure 24 shows the PWM output timing. When the counter becomes FFFh, the counter stops and output does not turn on until the next grayscale cycle. Pulling BLANK high before the counter becomes FFFh immediately resets the counter to zero.

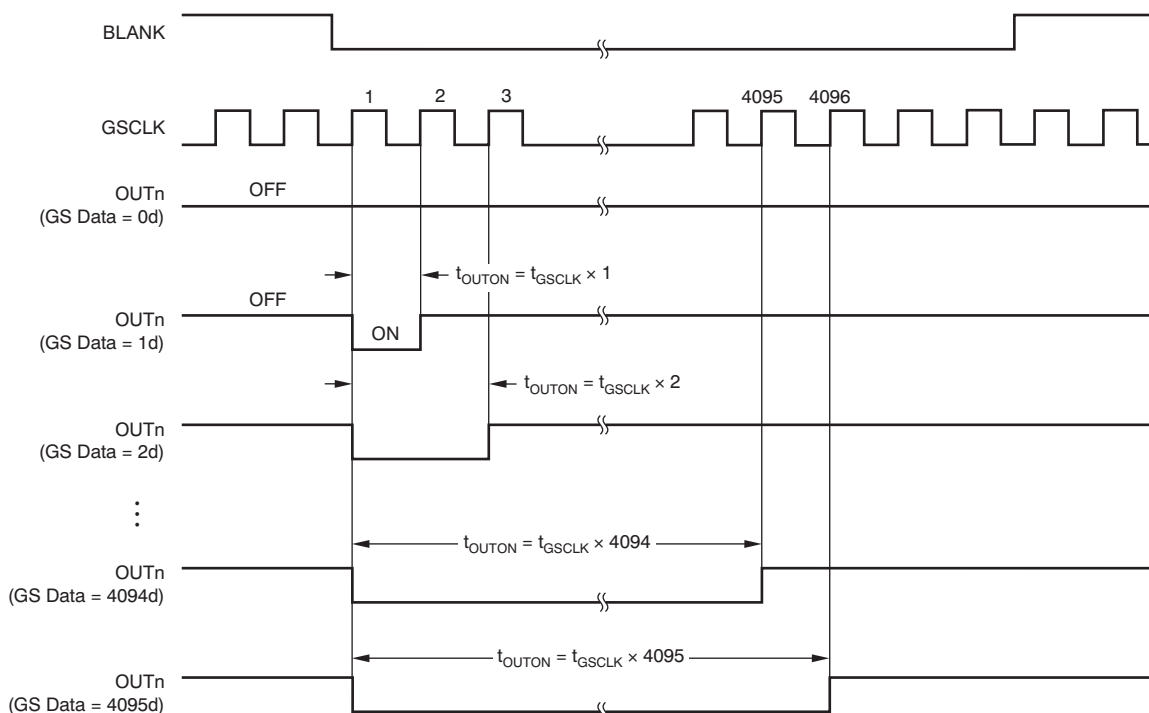

Figure 24. PWM Output Timing

When the IC powers on, the data in the shift register and latch are not set to any default value. Therefore, GS data must be written to the GS latch before turning the constant current output on. Additionally, BLANK should be high when the device is powered on, to prevent the outputs from turning on before the proper grayscale and dot correction values are written. All constant current outputs are always off when BLANK is high.

Each output (OUT_n) on-time (t_{OUTON}) is calculated by [Equation 3](#):

$$t_{\text{OUTON}} (\text{ns}) = t_{\text{GSCLK}} (\text{ns}) \times \text{GS}_n \quad (3)$$

Where:

- t_{GSCLK} = the period of GSCLK
- GS_n = the programmed grayscale value of output n ($\text{GS}_n = 0$ to $4095d$)

If XLAT goes high during a grayscale cycle, then new GS data are immediately latched into the GS latch. This action can cause the outputs to turn on or off unexpectedly. For proper operation, GS data should only be latched into the IC at the end of a GS period when BLANK is high.

When MODE is low, the input shift register works as a GS shift register. The shift registers and data latches are each 192 bits in length, and are used to set the PWM timing for each constant current driver. [Figure 25](#) shows the GS serial data configuration. Refer to [Figure 12](#) for a timing diagram for writing data into the shift register and latch. The driver on-time is set by the data in the GS data latch. GS data present on the SIN pin are clocked into the shift register with each rising edge of the SCLK pin. Data are shifted in MSB first. Data are latched from the shift register into the GS data latch with a rising edge on the XLAT pin.

When the IC powers on, the data in the shift register and data latch are not set to any default value. Therefore, grayscale data must be written to the GS latch before turning on the constant current output. Also, BLANK should be high when powered on because the constant current may also turn on. All constant current outputs are off when BLANK is high. The status information data (SID) byte overwrites on the most significant 17 bits of the input shift register at the rising edge of the first SCLK after XLAT goes low.

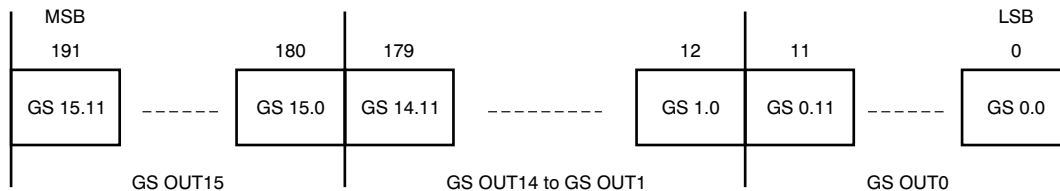

Figure 25. Grayscale Serial Data Configuration

STATUS INFORMATION DATA (SID)

Status information data (SID) are 17-bit, read-only data, accessible in the grayscale data input mode (MODE = GND). Both the LED open detection (LOD) error and the thermal error flag (TEF) are shifted out of the SOUT pin with each rising edge of SCLK. The 16 LOD bits for each channel and the TEF bit are written into the 17 most significant bits (MSBs) of the shift register at the rising edge of the first SCLK after XLAT goes low. As a result, the previous data in the 17 MSBs are lost at the same time. Figure 26 shows the bit assignments, Table 1 describes the SID data definition, and Figure 27 illustrates the read timing for the status information data.

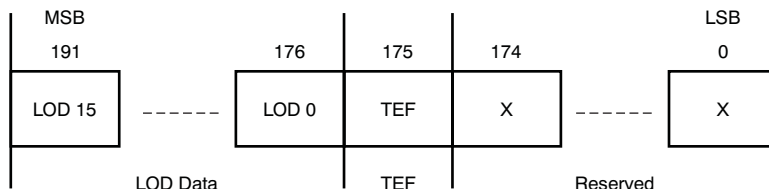

Figure 26. Status Information Data Configuration (XHALF = High)

Table 1. SID Data Definition

SID DATA	DEFINITION	
	LODn	TEF
0	No LED open error	No thermal error
1	LED is open or shorted to GND	Over temperature

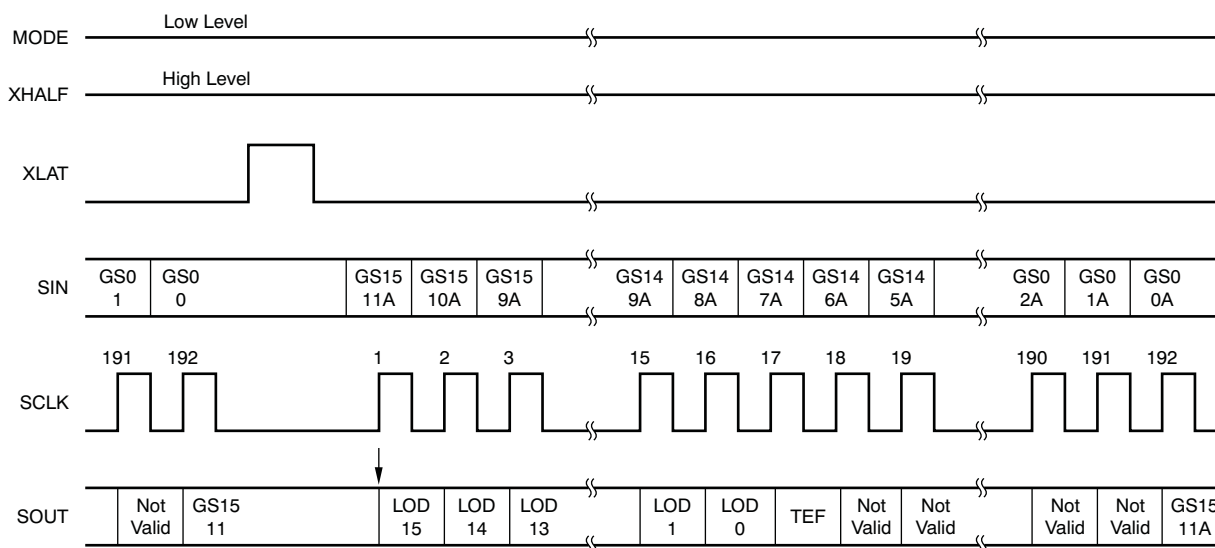

Figure 27. Status Information Data Read Timing (XHALF = High)

The LOD data are updated at the rising edge of the 33rd GSCLK pulse after BLANK goes low; the LOD data are retained until the next 33rd GSCLK. LOD data are only checked for outputs that are turned on during the rising edge of the 33rd GSCLK pulse. A '1' in a LOD bit indicates an open LED condition for the corresponding channel. A '0' indicates normal operation. The GS data should be equal to or higher than 21h (33d) to detect an open LED in every PWM cycle. When the IC is powered on, LOD data do not show correct values. Therefore, LOD data must be read at the rising edge of the 33rd GSCLK pulse after BLANK goes low.

The TEF bit indicates that the IC temperature is too high. A '1' in the TEF bit means that the IC temperature exceeds the detect temperature threshold, T_{TEF} . A '0' in the TEF bit indicates normal operating temperature conditions.

ERROR INFORMATION OUTPUT

The TLC5946 has two error detection circuits: LED open detection (LOD) and a thermal error flag (TEF). LOD detects a broken or disconnected LED during the display period. The TEF indicates an over-temperature condition. A low-level output of XERR indicates that an LOD error or TEF is detected. XERR pins of more than two ICs can be connected together and pulled up to V_{CC} with a single resistor because XERR is an open-drain output; see the [SCLK and GSCLK Frequency](#) section. [Table 2](#) shows the XERR truth table. BLANK = H masks LOD to distinguish between LOD and TEF. When the IC is powered on, XERR does not show correct values. XERR shows a correct signal when LOD data become valid at the rising edge of the 33rd GSCLK pulse after BLANK goes low. Also, both the LOD error and the TEF are shifted out of the SOUT pin; see the [Status Information Data \(SID\)](#) section.

Table 2. XERR Truth Table

CONDITION		INPUT	XERR
ERROR DATA			
LOD (Internal)	TEF (Internal)	BLANK	
0	0	L	H
0	1		L
1	0		L
1	1		L
0	0	H	H
0	1		L
1	0		H
1	1		L

CONTINUOUS BASE LED OPEN DETECTION (LOD)

The LOD function automatically updates LOD data at the rising edge of the 33rd GSCLK pulse after BLANK goes low; the LOD data are retained until the next 33rd GSCLK. LOD data are only checked for outputs that are turned on during the rising edge of the 33rd GSCLK pulse. The internal LOD data becomes '1' when the voltage of the OUTn pin is less than the LED open detection threshold ($V_{LOD} = 0.3$ V, typical).

To eliminate false detection of open LEDs, the LED driver design must ensure that the TLC5946 output voltage is greater than V_{LOD} when the outputs are on. The GS data should be equal to or higher than 21h (33d) to detect LED open in every PWM cycle.

AUTO OUTPUT OFF

The V_{CC} current (ICC) increases during an LED open detection. When the TLC5946 detects an open or shorted to ground LED at OUT_n , the TLC5946 turns off OUT_n to reduce the ICC at the 33rd falling edge of GSCLK after the falling edge of BLANK, as shown in Figure 28. This feature minimizes supply current during fault conditions. If there are any unconnected output LED lamps (including connection failures or short-circuits), the grayscale data corresponding to the unconnected output should be set to '0' before turning on the LEDs.

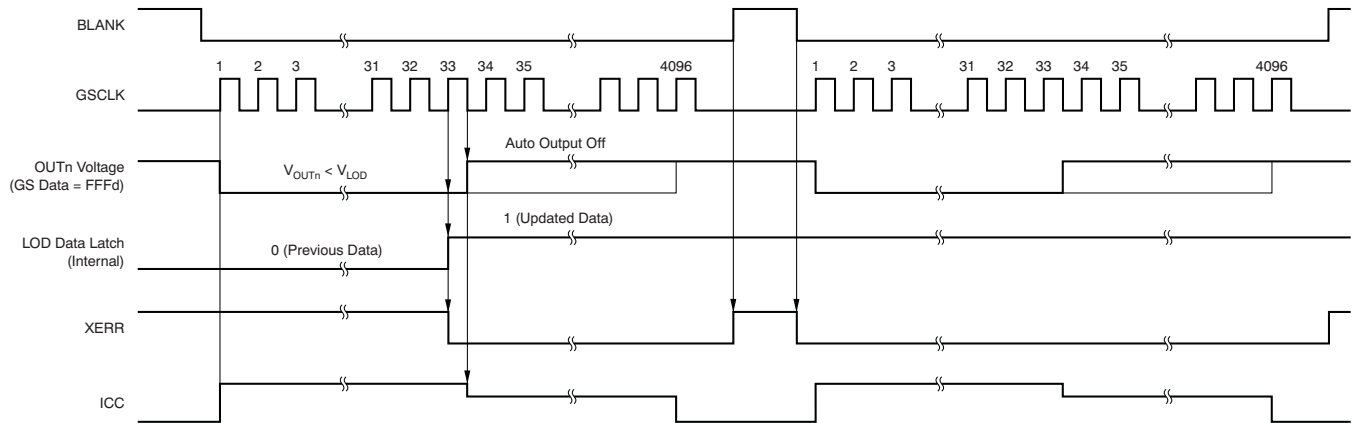

Figure 28. LOD and Auto Output Off Timing

THERMAL ERROR FLAG (TEF)

The TLC5946 has a thermal error flag (TEF) function to indicate an over-temperature condition. If the junction temperature exceeds the threshold temperature, +162°C typical, TEF toggles to '1' and the XERR pin goes to a low level. Once TEF becomes '1', it remains a '1' until the first falling edge of SCLK after XLAT goes low, as shown in Figure 29. If the junction temperature (T_J) remains higher than the threshold temperature, TEF remains '1', even after the first falling edge of SCLK. TEF is also shifted out of the SOUT pin; see the [Status Information Data \(SID\)](#) section.

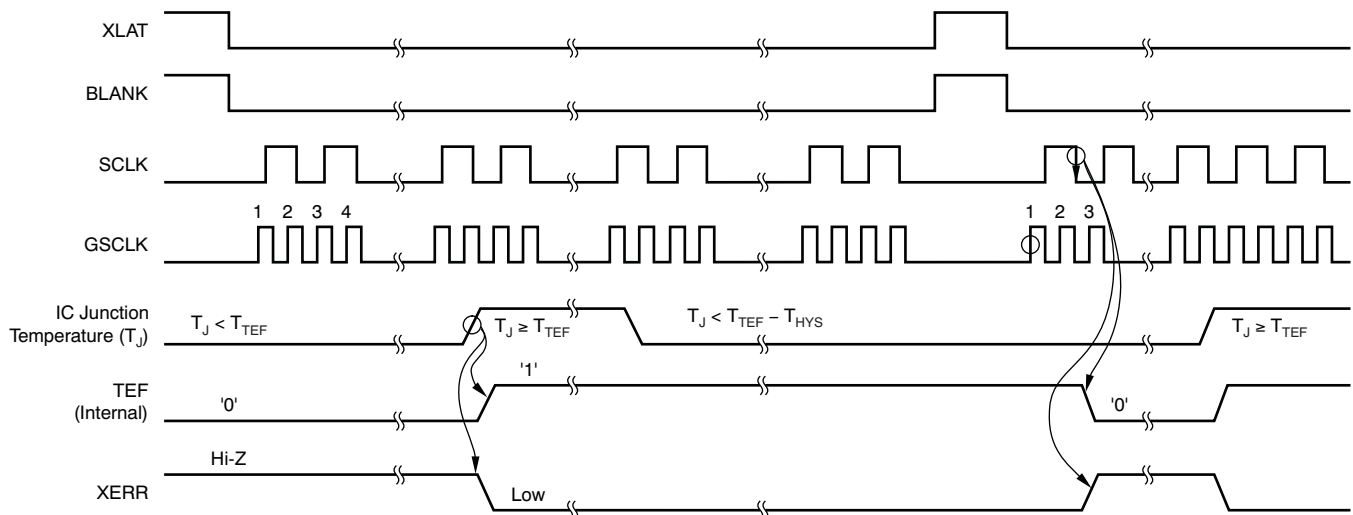

Figure 29. TEF and XERR Timing

NOISE REDUCTION

Large surge currents can flow through the IC and the board if all 16 LED channels fully turn on simultaneously at the start of each grayscale cycle. These large current surges could introduce detrimental noise and electromagnetic interference (EMI) into other circuits. The TLC5946 turns on the LED channels in a series delay, to provide a current soft-start feature. The output current sinks are grouped into four groups of four channels each. The first group is OUT0, 4, 8, 12; the second group is OUT1, 5, 9, 13; the third group is OUT2, 6, 10, 14; and the fourth group is OUT3, 7, 11, 15. Each group turns on sequentially with a small delay between groups; see [Figure 12](#). Both turn-on and turn-off are delayed.

OUTPUT ENABLE

When BLANK is high, all constant current outputs turn off and the grayscale counter is reset. When BLANK is low, all constant current outputs are controlled by the GS PWM timing controller. If BLANK goes low and then toggles high again in a very short time, all outputs that are programmed to turn on do so, for either the programmed number of grayscale clocks or the length of time that the BLANK signal was low, whichever is lower. For example, if all outputs are programmed to turn on for 1 ms, but the BLANK signal is only low for 50 ns, all outputs turn on for 50 ns, even though some outputs will turn on after the BLANK signal has already gone high.

SERIAL INTERFACE

The TLC5946 has a flexible serial interface that can be connected to microcontrollers or digital signal processors in various ways. Only three pins are needed to input data into the device. More than two TLC5946s can be connected in series by connecting an SOUT pin from one device to the SIN pin of the next device. Cascaded two TLC5946s are shown in Figure 30 and Figure 31. The SOUT pin can also be connected to the controller to receive status information from the TLC5946; see the *SCLK and GSCLK Frequency* section.

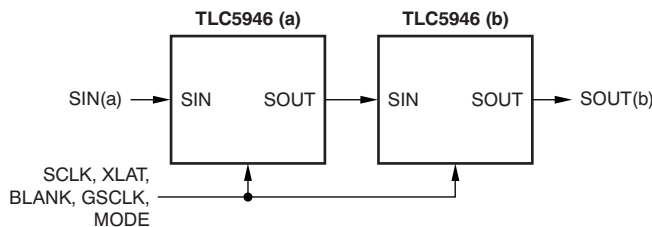

Figure 30. Cascading Two TLC5946 Devices

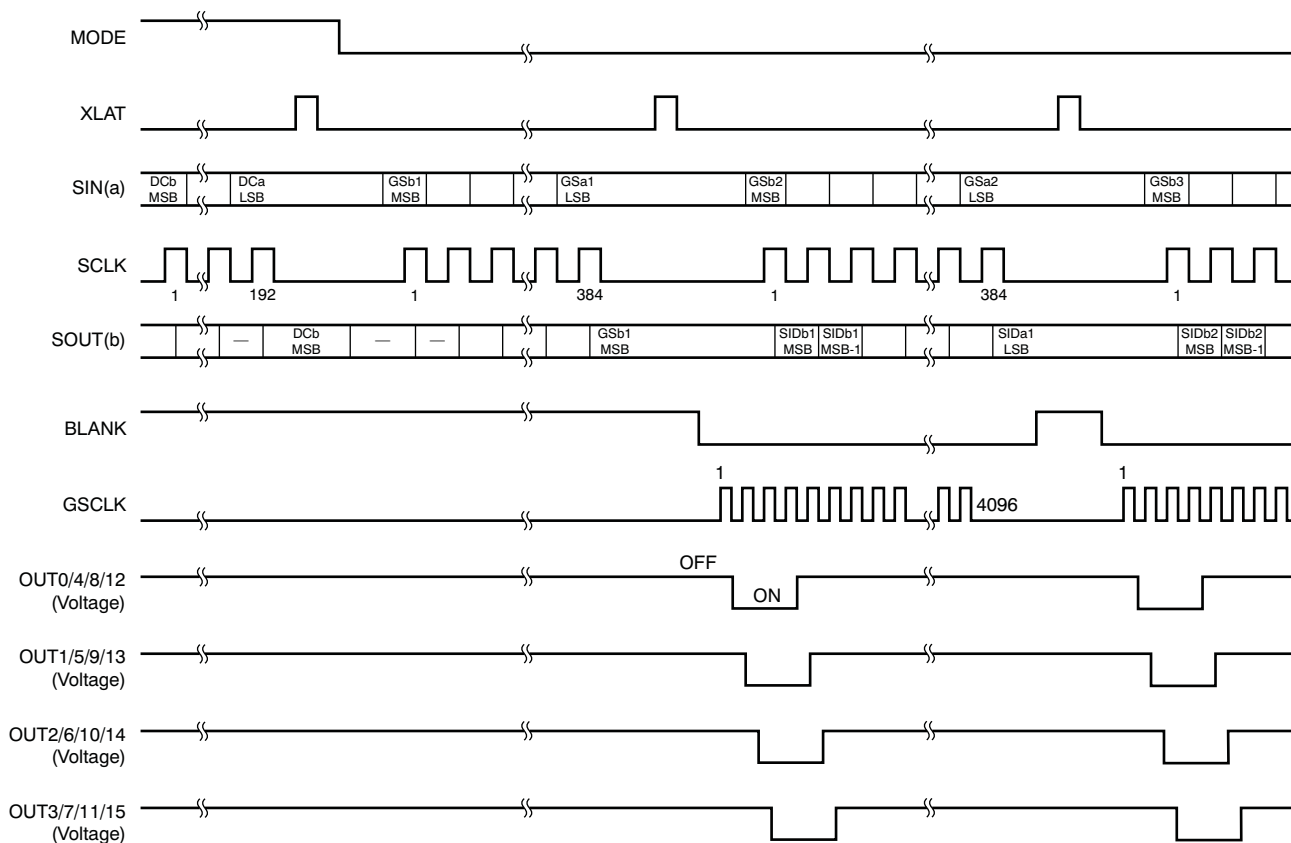

Figure 31. Timing Diagram of Two Cascaded TLC5946 Devices (XHALF = High)

SERIAL INTERFACE MODE

The serial interface has two input modes defined by the MODE pin, as Table 3 shows. XLAT must be low when the MODE pin goes high-to-low or low-to-high to change back and forth between GS mode and DC mode.

Table 3. Serial Interface Input Mode

MODE	INPUT MODE	INPUT SHIFT REGISTER
GND	Grayscale PWM data	192 bits
VCC	Dot correction data	96 bits

SCLK AND GSCLK FREQUENCY

Figure 32 shows a cascading connection of n TLC5946 devices connected to a single controller, building a basic module of an LED display system. There is no limitation to the maximum number of ICs that can be cascaded. However, the maximum number of cascading TLC5946 devices depends on the application system and is in the range of 40 devices. Equation 4 and Equation 5 show the minimum frequencies for GSCLK and SCLK.

$$f_{GSCLK} = 4096 \times f_{UPDATE} \tag{4}$$

$$f_{SCLK} = 192 \times f_{UPDATE} \times n \tag{5}$$

where:

- f_{GSCLK} = minimum frequency of GSCLK
- f_{SCLK} = minimum frequency of SCLK
- f_{UPDATE} = update rate of entire cascading system
- n = number of cascaded TLC5946 devices

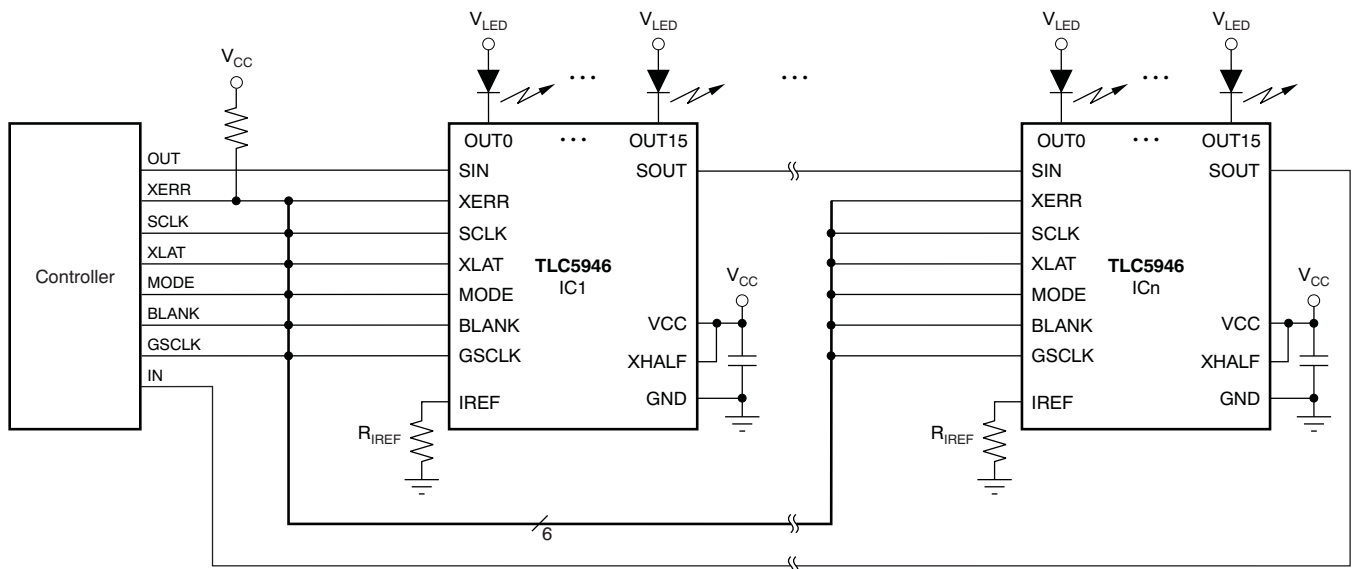

Figure 32. Cascading Device Connections

POWER DISSIPATION CALCULATION

The device power dissipation must be below the power dissipation rate of the device package to ensure correct operation. Equation 6 calculates the power dissipation of the device:

$$P_D = (V_{CC} \times I_{CC}) + \left[V_{OUT} \times I_{OLC_{max}} \times N \times \frac{DC_n}{63d} \times d_{PWM} \right] \quad (6)$$

Where:

- P_D = device power dissipation
- V_{CC} = device supply voltage
- I_{CC} = device supply current
- V_{OUT} = OUTn voltage when driving LED current
- $I_{OLC_{max}}$ = LED current adjusted by R_{IREF} resistor
- DC_n = maximum DC value for OUTn
- N = number of OUTn driving LED at the same time
- d_{PWM} = duty cycle defined by BLANK pin or GS PWM value

EXTENDED SERIAL INTERFACE

The TLC5946 has an extended serial interface with the following functions:

1. Independently accessible GS shift register of OUT0 to OUT7 or OUT8 to OUT15
2. SOUT half clock delay

When XHALF is low, the extended serial interface becomes active. Either the OUT0 to OUT7 GS shift register or the OUT8 to OUT15 GS shift register is selected in advance by counting the XLAT pulses while BLANK is high (one XLAT pulse selects the OUT0 to OUT7 GS shift register and two XLAT pulses select the OUT8 to OUT15 GS shift register), as shown in Figure 33. One or two XLAT pulses while BLANK is high must be input before sending the serial data.

SOUT outputs serial data at the falling edge of SCLK, delaying half a clock longer than the normal serial interface mode. SIN reads data at the rising edge of SCLK at the same as the normal serial interface mode. This configuration ensures a longer distance serial interface. Figure 34 shows the output timing of the extended serial interface mode.

SOUT outputs the status information data only when the data of OUT8 to OUT15 are shifted in, as shown in Figure 35 and Figure 36. The status information data configuration when XHALF is low is shown in Figure 37.

Figure 38 shows the recommended ac timing widths of the extended serial interface. Note that t_{WL2} , t_{SU7} , and t_{H3} are only effective when XHALF is low.

Figure 39 and Figure 40 are power-on sequence examples of this mode. BLANK should be high when the device is powered on to prevent the outputs from turning on before the proper GS and DC values are written. The extended serial interface mode is available only in the GS PWM mode (MODE = low). When MODE is high in the extended serial interface mode (XHALF = low), the TLC5946 becomes the DC mode that is the same as the normal DC mode.

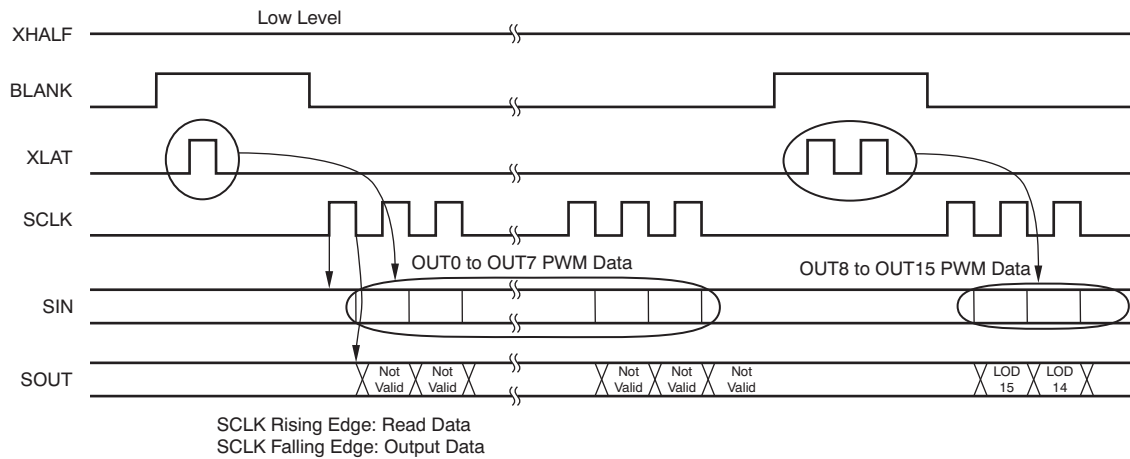

Figure 33. Extended Serial Interface

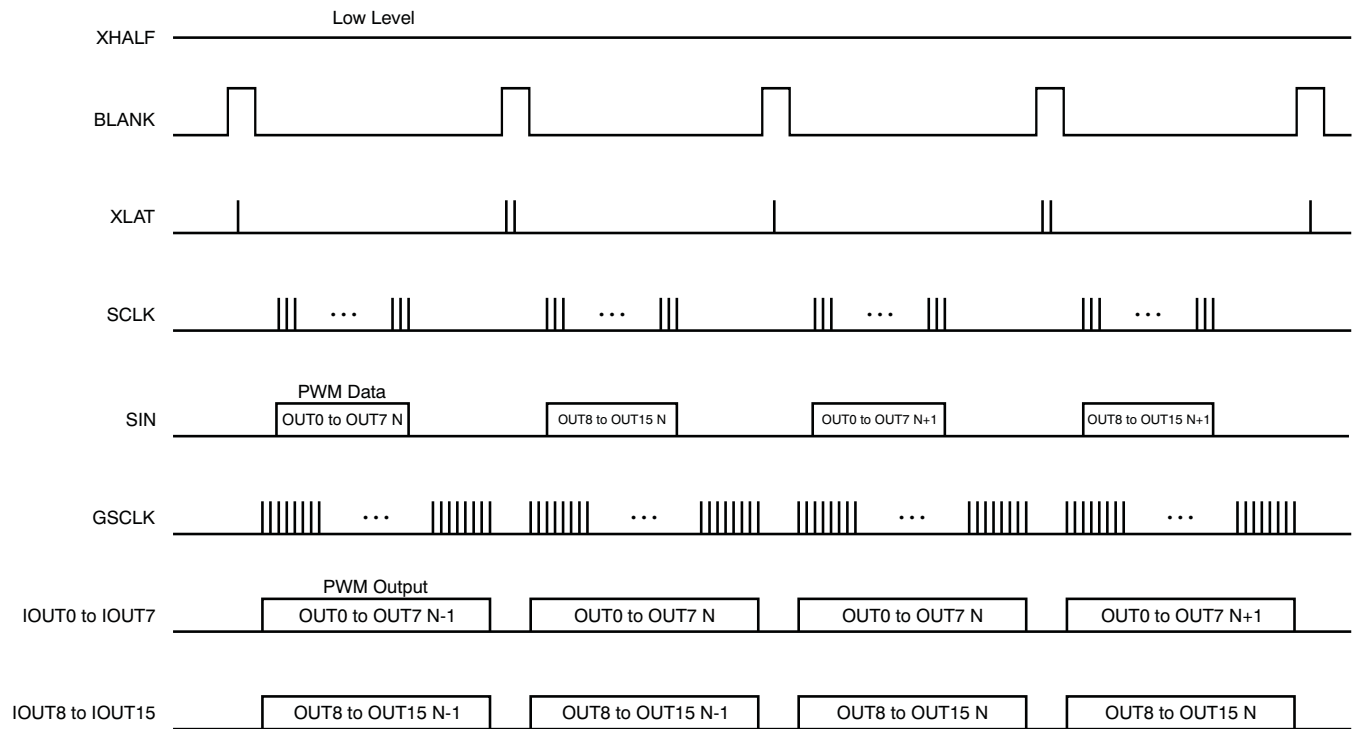

Figure 34. Output Timing of Extended Serial Interface

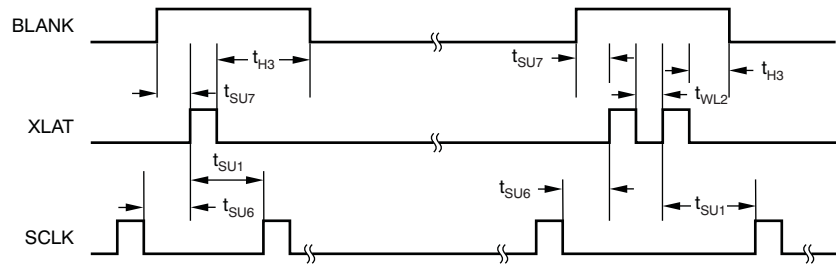
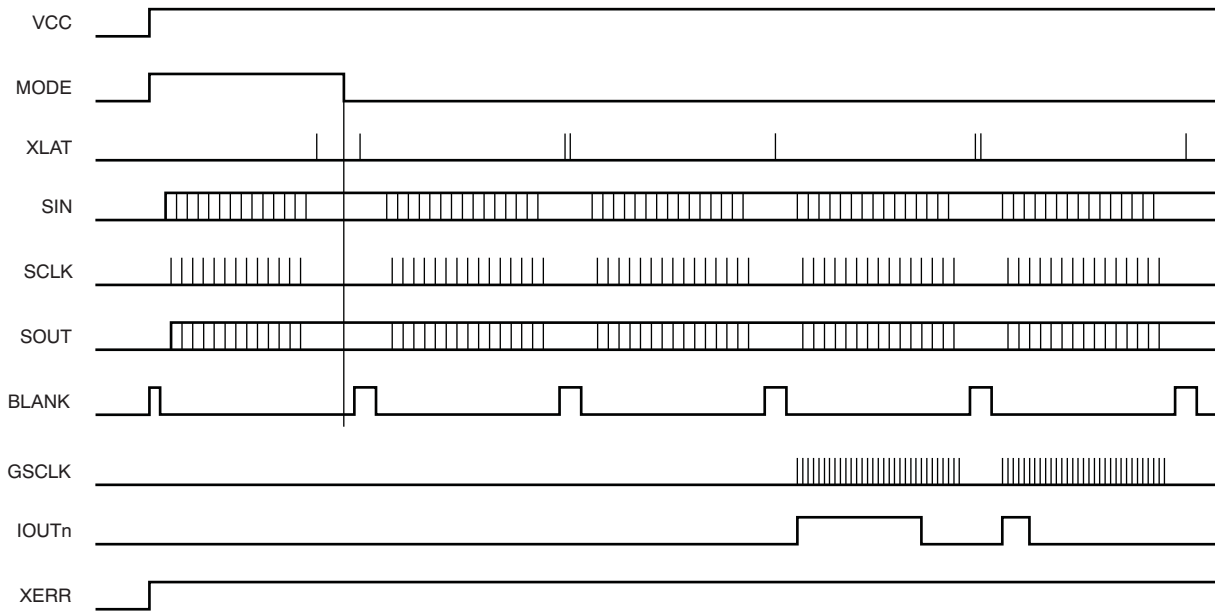
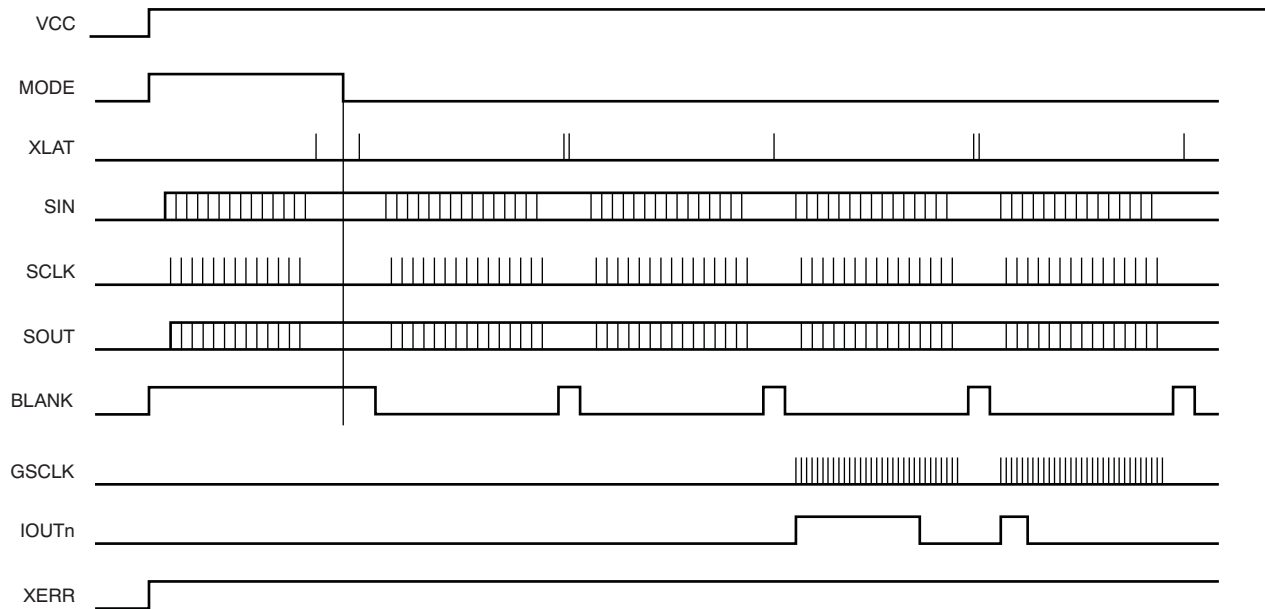

Figure 38. AC Timing in Extended Serial Interface Mode (XHALF = Low)



**Figure 39. Power-On Sequence—1 (XHALF = Low)
(BLANK goes high immediately after power-on)**



**Figure 40. Power-On Sequence—2 (XHALF = Low)
(BLANK stays high after power-on, GS mode starts with BLANK = High)**

Revision History

Changes from Revision A (April 2008) to Revision B	Page
• Changed device status from Mixed Status to Production Data for QFN package	1
• Updated front page graphic	1
• Deleted footnote 2 from <i>Package/Ordering Information</i> table; device status for the TLC5946RHB is now Production Data.....	2
• Updated Figure 32	22
Changes from Revision original (March 2008) to Revision A	Page
• Added footnote 2 to Package/Ordering Information table to indicate device status for the TLC5946RHB is now Product Preview	2

PACKAGING INFORMATION

Orderable Device	Status ⁽¹⁾	Package Type	Package Drawing	Pins	Package Qty	Eco Plan ⁽²⁾	Lead/Ball Finish	MSL Peak Temp ⁽³⁾
TLC5946PW	ACTIVE	TSSOP	PW	28	50	Green (RoHS & no Sb/Br)	CU NIPDAU	Level-1-260C-UNLIM
TLC5946PWG4	ACTIVE	TSSOP	PW	28	50	Green (RoHS & no Sb/Br)	CU NIPDAU	Level-1-260C-UNLIM
TLC5946PWP	ACTIVE	HTSSOP	PWP	28	50	Green (RoHS & no Sb/Br)	CU NIPDAU	Level-2-260C-1 YEAR
TLC5946PWPG4	ACTIVE	HTSSOP	PWP	28	50	Green (RoHS & no Sb/Br)	CU NIPDAU	Level-2-260C-1 YEAR
TLC5946PWPR	ACTIVE	HTSSOP	PWP	28	2000	Green (RoHS & no Sb/Br)	CU NIPDAU	Level-2-260C-1 YEAR
TLC5946PWPRG4	ACTIVE	HTSSOP	PWP	28	2000	Green (RoHS & no Sb/Br)	CU NIPDAU	Level-2-260C-1 YEAR
TLC5946PWR	ACTIVE	TSSOP	PW	28	2000	Green (RoHS & no Sb/Br)	CU NIPDAU	Level-1-260C-UNLIM
TLC5946PWRG4	ACTIVE	TSSOP	PW	28	2000	Green (RoHS & no Sb/Br)	CU NIPDAU	Level-1-260C-UNLIM
TLC5946RHBR	ACTIVE	QFN	RHB	32	3000	Green (RoHS & no Sb/Br)	CU NIPDAU	Level-2-260C-1 YEAR
TLC5946RHBRG4	ACTIVE	QFN	RHB	32	3000	Green (RoHS & no Sb/Br)	CU NIPDAU	Level-2-260C-1 YEAR
TLC5946RHBT	ACTIVE	QFN	RHB	32	250	Green (RoHS & no Sb/Br)	CU NIPDAU	Level-2-260C-1 YEAR
TLC5946RHBTG4	ACTIVE	QFN	RHB	32	250	Green (RoHS & no Sb/Br)	CU NIPDAU	Level-2-260C-1 YEAR

⁽¹⁾ The marketing status values are defined as follows:

ACTIVE: Product device recommended for new designs.

LIFEBUY: TI has announced that the device will be discontinued, and a lifetime-buy period is in effect.

NRND: Not recommended for new designs. Device is in production to support existing customers, but TI does not recommend using this part in a new design.

PREVIEW: Device has been announced but is not in production. Samples may or may not be available.

OBSOLETE: TI has discontinued the production of the device.

⁽²⁾ Eco Plan - The planned eco-friendly classification: Pb-Free (RoHS), Pb-Free (RoHS Exempt), or Green (RoHS & no Sb/Br) - please check <http://www.ti.com/productcontent> for the latest availability information and additional product content details.

TBD: The Pb-Free/Green conversion plan has not been defined.

Pb-Free (RoHS): TI's terms "Lead-Free" or "Pb-Free" mean semiconductor products that are compatible with the current RoHS requirements for all 6 substances, including the requirement that lead not exceed 0.1% by weight in homogeneous materials. Where designed to be soldered at high temperatures, TI Pb-Free products are suitable for use in specified lead-free processes.

Pb-Free (RoHS Exempt): This component has a RoHS exemption for either 1) lead-based flip-chip solder bumps used between the die and package, or 2) lead-based die adhesive used between the die and leadframe. The component is otherwise considered Pb-Free (RoHS compatible) as defined above.

Green (RoHS & no Sb/Br): TI defines "Green" to mean Pb-Free (RoHS compatible), and free of Bromine (Br) and Antimony (Sb) based flame retardants (Br or Sb do not exceed 0.1% by weight in homogeneous material)

⁽³⁾ MSL, Peak Temp. -- The Moisture Sensitivity Level rating according to the JEDEC industry standard classifications, and peak solder temperature.

Important Information and Disclaimer: The information provided on this page represents TI's knowledge and belief as of the date that it is provided. TI bases its knowledge and belief on information provided by third parties, and makes no representation or warranty as to the accuracy of such information. Efforts are underway to better integrate information from third parties. TI has taken and continues to take reasonable steps to provide representative and accurate information but may not have conducted destructive testing or chemical analysis on incoming materials and chemicals. TI and TI suppliers consider certain information to be proprietary, and thus CAS numbers and other limited information may not be available for release.

In no event shall TI's liability arising out of such information exceed the total purchase price of the TI part(s) at issue in this document sold by TI to Customer on an annual basis.

TAPE AND REEL INFORMATION



QUADRANT ASSIGNMENTS FOR PIN 1 ORIENTATION IN TAPE



*All dimensions are nominal

Device	Package Type	Package Drawing	Pins	SPQ	Reel Diameter (mm)	Reel Width W1 (mm)	A0 (mm)	B0 (mm)	K0 (mm)	P1 (mm)	W (mm)	Pin1 Quadrant
TLC5946RHBR	QFN	RHB	32	3000	330.0	12.4	5.3	5.3	1.5	8.0	12.0	Q2
TLC5946RHBT	QFN	RHB	32	250	180.0	12.4	5.3	5.3	1.5	8.0	12.0	Q2

TAPE AND REEL BOX DIMENSIONS

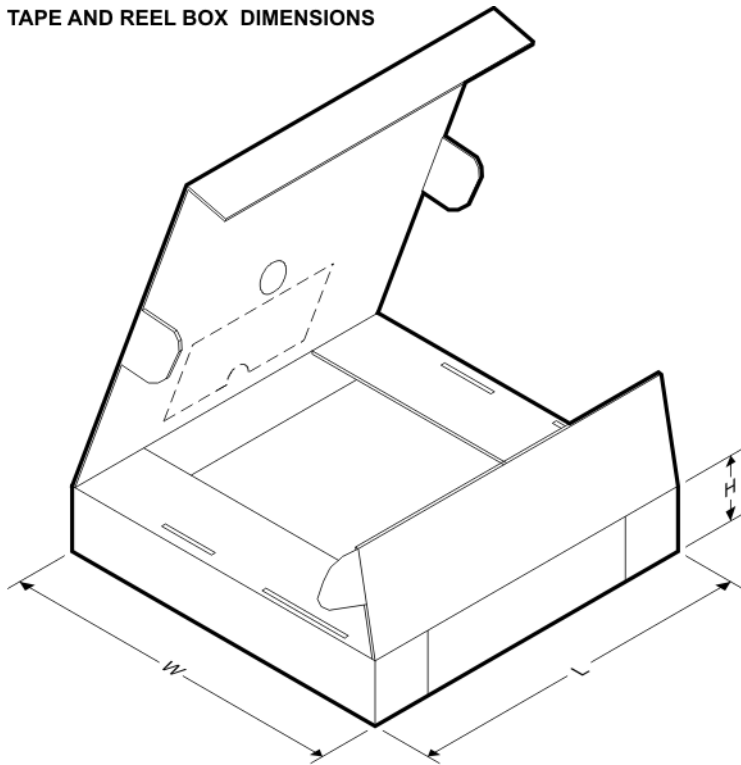

*All dimensions are nominal

Device	Package Type	Package Drawing	Pins	SPQ	Length (mm)	Width (mm)	Height (mm)
TLC5946RHBR	QFN	RHB	32	3000	346.0	346.0	29.0
TLC5946RHBT	QFN	RHB	32	250	190.5	212.7	31.8

PW (R-PDSO-G**)

PLASTIC SMALL-OUTLINE PACKAGE

14 PINS SHOWN



4040064/F 01/97

- NOTES: A. All linear dimensions are in millimeters.
 B. This drawing is subject to change without notice.
 C. Body dimensions do not include mold flash or protrusion not to exceed 0,15.
 D. Falls within JEDEC MO-153

RHB (S-PQFP-N32)

PLASTIC QUAD FLATPACK

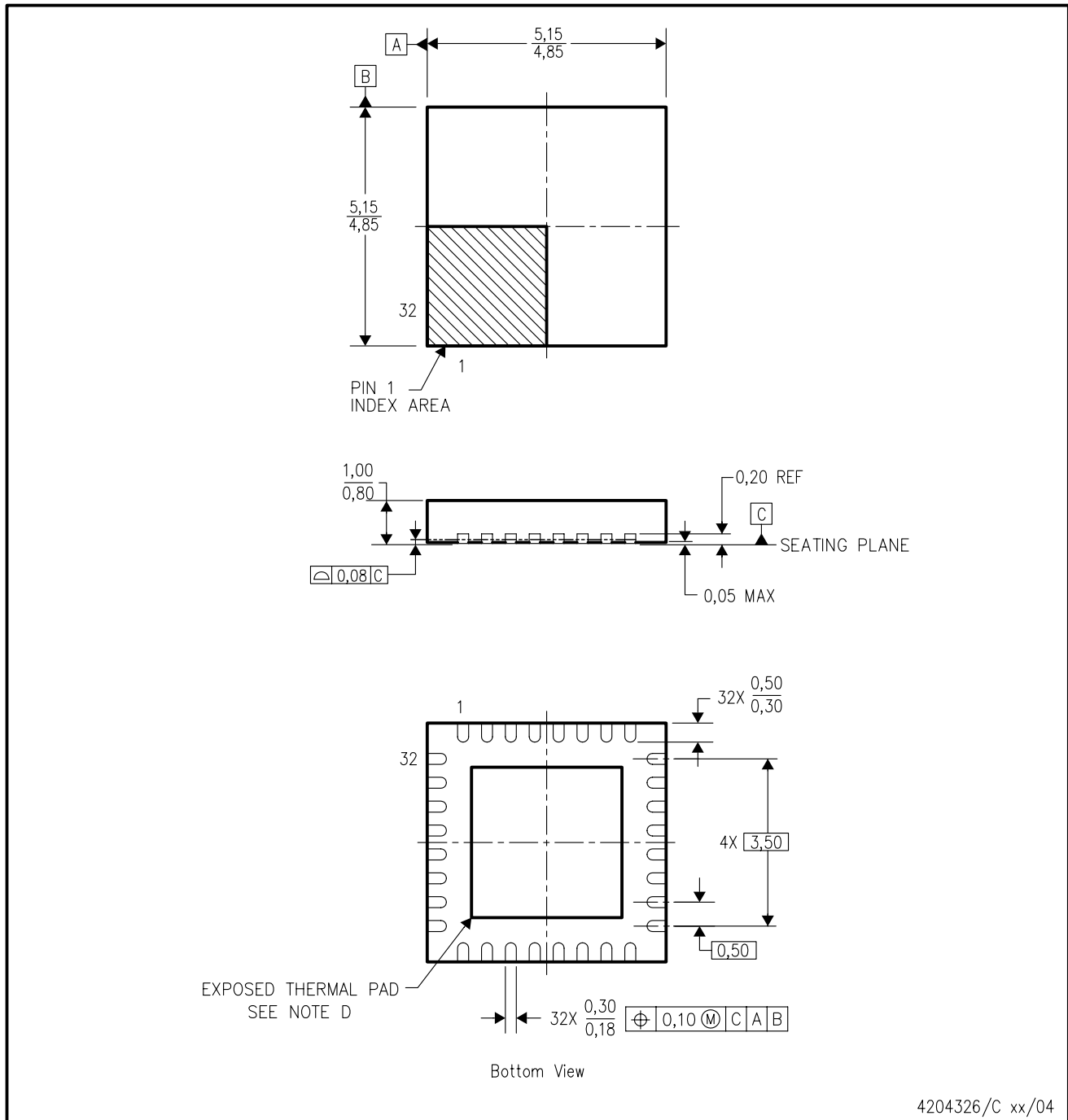

- NOTES:
- All linear dimensions are in millimeters.
 - This drawing is subject to change without notice.
 - QFN (Quad Flatpack No-Lead) Package configuration.
 - The Package thermal pad must be soldered to the board for thermal and mechanical performance. See product data sheet for details regarding the exposed thermal pad dimensions.
 - Falls within JEDEC MO-220.

THERMAL INFORMATION

This package incorporates an exposed thermal pad that is designed to be attached directly to an external heatsink. The thermal pad must be soldered directly to the printed circuit board (PCB). After soldering, the PCB can be used as a heatsink. In addition, through the use of thermal vias, the thermal pad can be attached directly to the appropriate copper plane shown in the electrical schematic for the device, or alternatively, can be attached to a special heatsink structure designed into the PCB. This design optimizes the heat transfer from the integrated circuit (IC).

For information on the Quad Flatpack No-Lead (QFN) package and its advantages, refer to Application Report, QFN/SON PCB Attachment, Texas Instruments Literature No. SLUA271. This document is available at www.ti.com.

The exposed thermal pad dimensions for this package are shown in the following illustration.

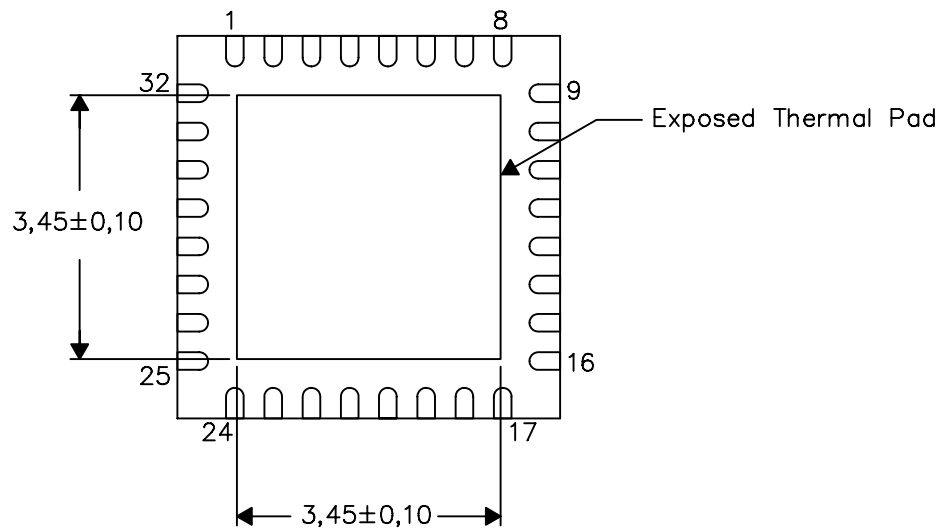

Bottom View

NOTE: All linear dimensions are in millimeters

Exposed Thermal Pad Dimensions

RHB (S-PQFP-N32)

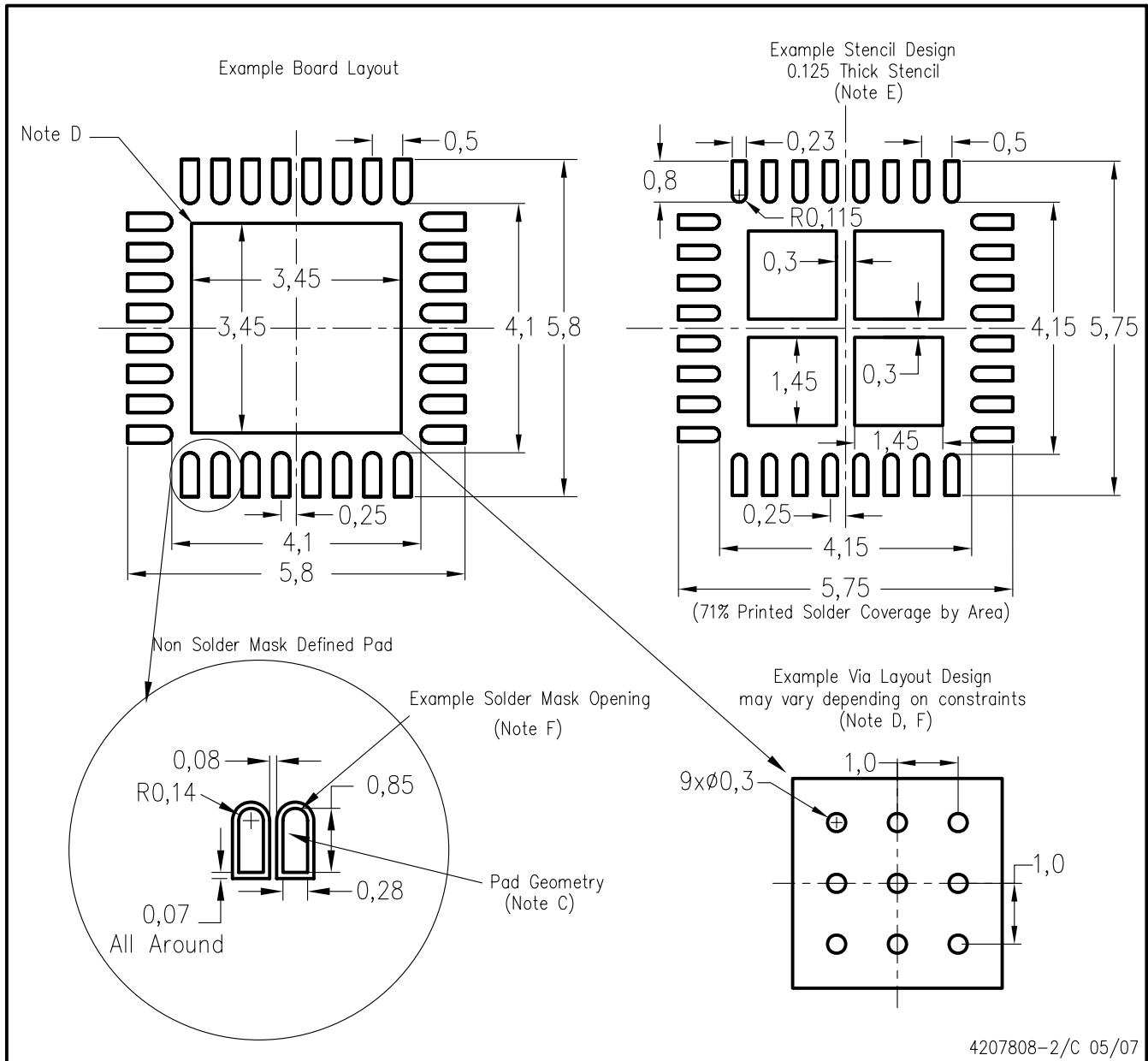

4207808-2/C 05/07

- NOTES:
- A. All linear dimensions are in millimeters.
 - B. This drawing is subject to change without notice.
 - C. Publication IPC-7351 is recommended for alternate designs.
 - D. This package is designed to be soldered to a thermal pad on the board. Refer to Application Note, Quad Flat-Pack Packages, Texas Instruments Literature No. SCBA017, SLUA271, and also the Product Data Sheets for specific thermal information, via requirements, and recommended board layout. These documents are available at www.ti.com <<http://www.ti.com>>.
 - E. Laser cutting apertures with trapezoidal walls and also rounding corners will offer better paste release. Customers should contact their board assembly site for stencil design recommendations. Refer to IPC 7525 for stencil design considerations.
 - F. Customers should contact their board fabrication site for recommended solder mask tolerances and via tenting recommendations for vias placed in the thermal pad.

PWP (R-PDSO-G**) 20 PIN SHOWN

PowerPAD™ PLASTIC SMALL-OUTLINE PACKAGE

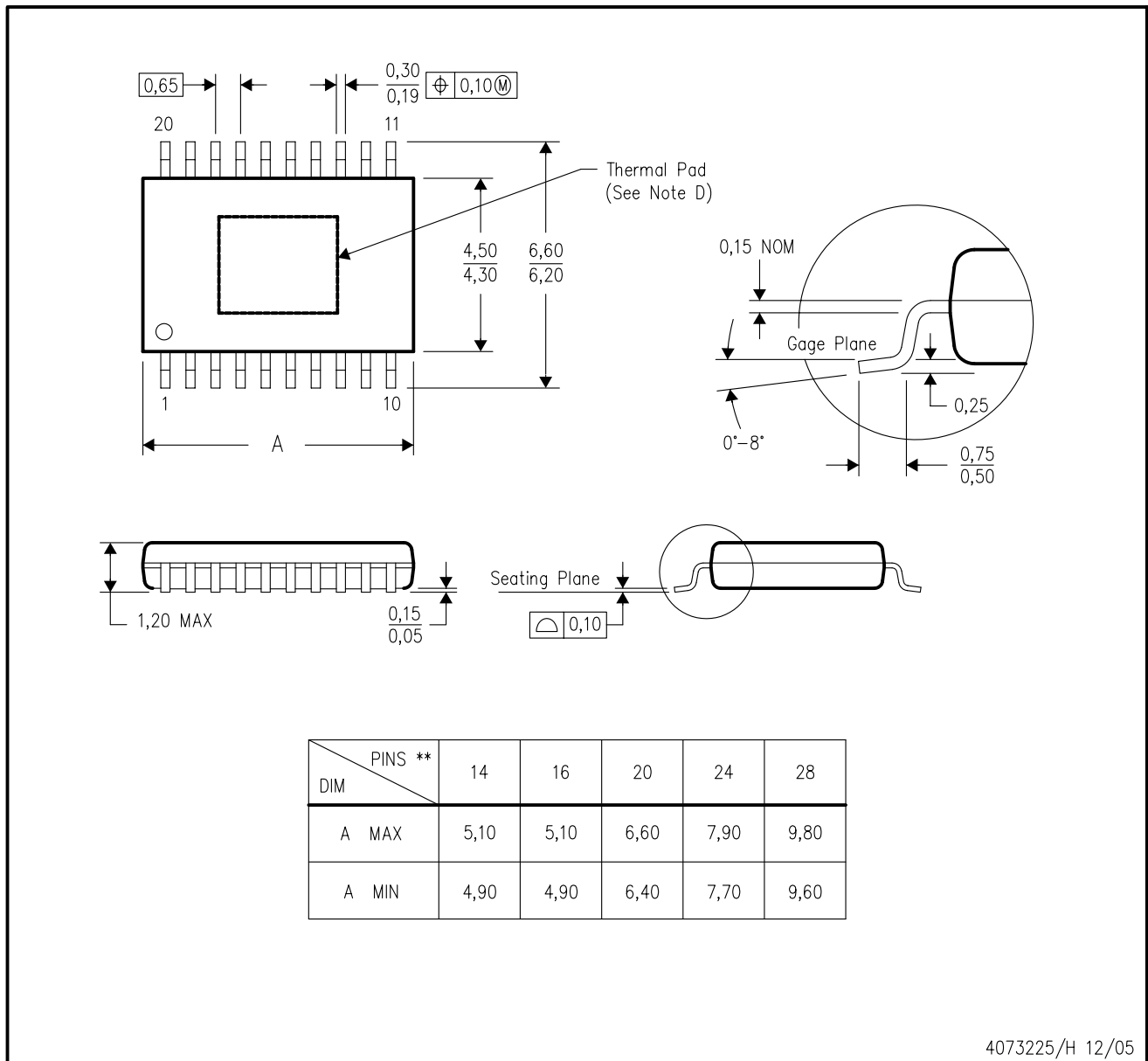

4073225/H 12/05

- NOTES:
- A. All linear dimensions are in millimeters.
 - B. This drawing is subject to change without notice.
 - C. Body dimensions do not include mold flash or protrusions. Mold flash and protrusion shall not exceed 0.15 per side.
 - D. This package is designed to be soldered to a thermal pad on the board. Refer to Technical Brief, PowerPad Thermally Enhanced Package, Texas Instruments Literature No. SLMA002 for information regarding recommended board layout. This document is available at www.ti.com <<http://www.ti.com>>.
 - E. Falls within JEDEC MO-153

PowerPAD is a trademark of Texas Instruments.

THERMAL INFORMATION

This PowerPAD™ package incorporates an exposed thermal pad that is designed to be attached to a printed circuit board (PCB). The thermal pad must be soldered directly to the PCB. After soldering, the PCB can be used as a heatsink. In addition, through the use of thermal vias, the thermal pad can be attached directly to the appropriate copper plane shown in the electrical schematic for the device, or alternatively, can be attached to a special heatsink structure designed into the PCB. This design optimizes the heat transfer from the integrated circuit (IC).

For additional information on the PowerPAD package and how to take advantage of its heat dissipating abilities, refer to Technical Brief, PowerPAD Thermally Enhanced Package, Texas Instruments Literature No. SLMA002 and Application Brief, PowerPAD Made Easy, Texas Instruments Literature No. SLMA004. Both documents are available at www.ti.com.

The exposed thermal pad dimensions for this package are shown in the following illustration.

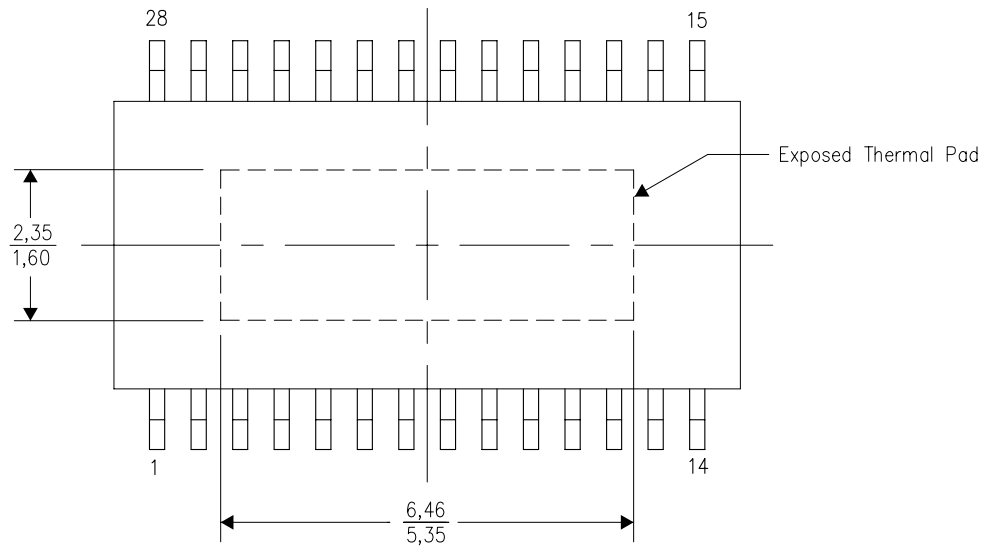

Top View

NOTE: All linear dimensions are in millimeters

Exposed Thermal Pad Dimensions

PWP (R-PDSO-G28) PowerPAD™

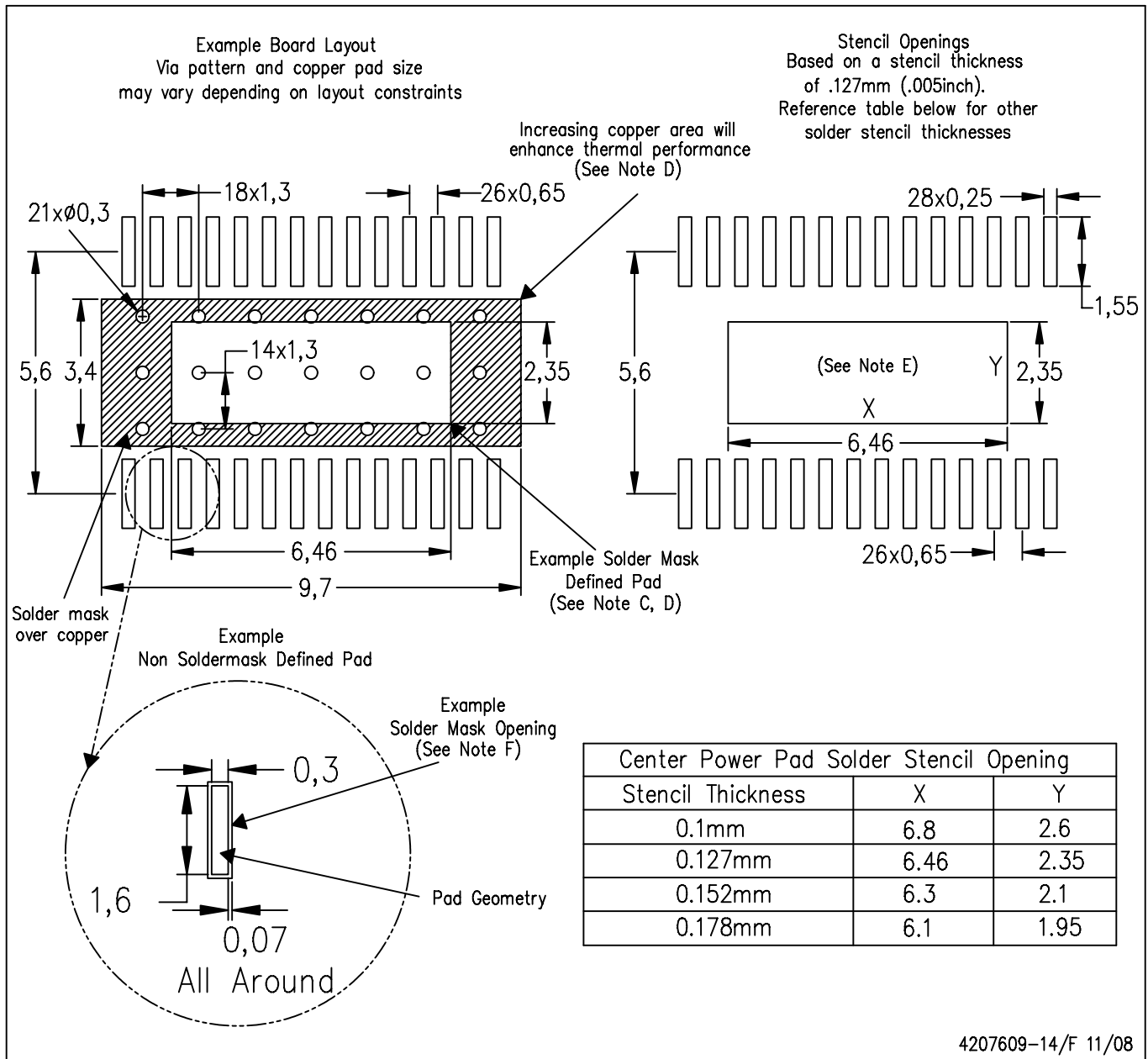

- NOTES:
- All linear dimensions are in millimeters.
 - This drawing is subject to change without notice.
 - Customers should place a note on the circuit board fabrication drawing not to alter the center solder mask defined pad.
 - This package is designed to be soldered to a thermal pad on the board. Refer to Technical Brief, PowerPad Thermally Enhanced Package, Texas Instruments Literature No. SLMA002, SLMA004, and also the Product Data Sheets for specific thermal information, via requirements, and recommended board layout. These documents are available at www.ti.com <<http://www.ti.com>>. Publication IPC-7351 is recommended for alternate designs.
 - Laser cutting apertures with trapezoidal walls and also rounding corners will offer better paste release. Customers should contact their board assembly site for stencil design recommendations. Example stencil design based on a 50% volumetric metal load solder paste. Refer to IPC-7525 for other stencil recommendations.
 - Customers should contact their board fabrication site for solder mask tolerances between and around signal pads.
- PowerPAD is a trademark of Texas Instruments.

IMPORTANT NOTICE

Texas Instruments Incorporated and its subsidiaries (TI) reserve the right to make corrections, modifications, enhancements, improvements, and other changes to its products and services at any time and to discontinue any product or service without notice. Customers should obtain the latest relevant information before placing orders and should verify that such information is current and complete. All products are sold subject to TI's terms and conditions of sale supplied at the time of order acknowledgment.

TI warrants performance of its hardware products to the specifications applicable at the time of sale in accordance with TI's standard warranty. Testing and other quality control techniques are used to the extent TI deems necessary to support this warranty. Except where mandated by government requirements, testing of all parameters of each product is not necessarily performed.

TI assumes no liability for applications assistance or customer product design. Customers are responsible for their products and applications using TI components. To minimize the risks associated with customer products and applications, customers should provide adequate design and operating safeguards.

TI does not warrant or represent that any license, either express or implied, is granted under any TI patent right, copyright, mask work right, or other TI intellectual property right relating to any combination, machine, or process in which TI products or services are used. Information published by TI regarding third-party products or services does not constitute a license from TI to use such products or services or a warranty or endorsement thereof. Use of such information may require a license from a third party under the patents or other intellectual property of the third party, or a license from TI under the patents or other intellectual property of TI.

Reproduction of TI information in TI data books or data sheets is permissible only if reproduction is without alteration and is accompanied by all associated warranties, conditions, limitations, and notices. Reproduction of this information with alteration is an unfair and deceptive business practice. TI is not responsible or liable for such altered documentation. Information of third parties may be subject to additional restrictions.

Resale of TI products or services with statements different from or beyond the parameters stated by TI for that product or service voids all express and any implied warranties for the associated TI product or service and is an unfair and deceptive business practice. TI is not responsible or liable for any such statements.

TI products are not authorized for use in safety-critical applications (such as life support) where a failure of the TI product would reasonably be expected to cause severe personal injury or death, unless officers of the parties have executed an agreement specifically governing such use. Buyers represent that they have all necessary expertise in the safety and regulatory ramifications of their applications, and acknowledge and agree that they are solely responsible for all legal, regulatory and safety-related requirements concerning their products and any use of TI products in such safety-critical applications, notwithstanding any applications-related information or support that may be provided by TI. Further, Buyers must fully indemnify TI and its representatives against any damages arising out of the use of TI products in such safety-critical applications.

TI products are neither designed nor intended for use in military/aerospace applications or environments unless the TI products are specifically designated by TI as military-grade or "enhanced plastic." Only products designated by TI as military-grade meet military specifications. Buyers acknowledge and agree that any such use of TI products which TI has not designated as military-grade is solely at the Buyer's risk, and that they are solely responsible for compliance with all legal and regulatory requirements in connection with such use.

TI products are neither designed nor intended for use in automotive applications or environments unless the specific TI products are designated by TI as compliant with ISO/TS 16949 requirements. Buyers acknowledge and agree that, if they use any non-designated products in automotive applications, TI will not be responsible for any failure to meet such requirements.

Following are URLs where you can obtain information on other Texas Instruments products and application solutions:

Products

Amplifiers	amplifier.ti.com
Data Converters	dataconverter.ti.com
DSP	dsp.ti.com
Clocks and Timers	www.ti.com/clocks
Interface	interface.ti.com
Logic	logic.ti.com
Power Mgmt	power.ti.com
Microcontrollers	microcontroller.ti.com
RFID	www.ti-rfid.com
RF/IF and ZigBee® Solutions	www.ti.com/lprf

Applications

Audio	www.ti.com/audio
Automotive	www.ti.com/automotive
Broadband	www.ti.com/broadband
Digital Control	www.ti.com/digitalcontrol
Medical	www.ti.com/medical
Military	www.ti.com/military
Optical Networking	www.ti.com/opticalnetwork
Security	www.ti.com/security
Telephony	www.ti.com/telephony
Video & Imaging	www.ti.com/video
Wireless	www.ti.com/wireless

Mailing Address: Texas Instruments, Post Office Box 655303, Dallas, Texas 75265
Copyright © 2008, Texas Instruments Incorporated